

Overview

TF-706 Transmitter

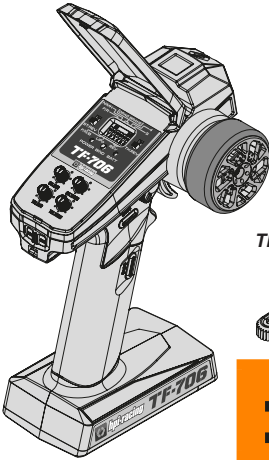

Thumb Lever

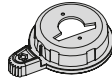

i 5-3

Equipment Needed

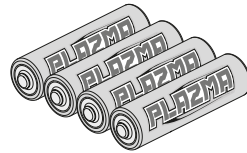

101939

PLAZMA 1.5V Alkaline AA Battery

RF-706 Receiver

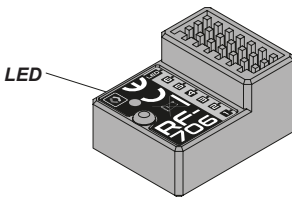

LED

SRL-706 Receiver

LED

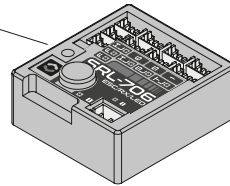

OR



Cautions

Failure to follow these instructions can damage your kit, and cause serious bodily injury or death.



Attention

Failure to follow these instructions can cause injury to yourself or others. You might also cause property damage or damage your kit.

Operating Suggestions

Be sure to thoroughly read and understand these instructions before using this product. Pay particular attention to the items labeled **Caution** and **Attention**. Failure to follow these instructions may result in damage to your RC car and injury to yourself and other people.



Caution

If you make changes or adjustments not shown in the instruction manual, your vehicle may be damaged.

Safety Guidelines about Products

- Turn on the transmitter first then the receiver. Turn off the receiver first then the transmitter.
- Before running you must check the radio function.
- This radio is made of precision electronics, do not expose to extreme heat, vibration, shock or water
- Do not cut antenna wire.
- 2.4GHz radio frequency only functions by line of sight, if you drive behind a solid object or around a corner and lose sight of the vehicle you may lose control of the RC car.



Caution

If you make changes or adjustments not shown in the instruction manual, your vehicle may be damaged.

Safety Guidelines when Operating Products

- Turn on the transmitter first then the receiver. Turn off the receiver first then the transmitter.
- Be careful to not short circuit any of the wires as this will cause damage to the unit.
- After running, the motor, ESC and wires may be hot. Do not touch as they can cause burns.
- Do not disassemble and make any modifications to the transmitter and receiver/ESC.

1 Transmitter Features

Steering Reverse Switch:
Change Operation direction of steering channel

i 4-4

DIP Switches:
Change settings of RFL-706 ESC

i 4-3, 7

Steering Wheel

i 3-3

Throttle Reverse Switch:
Change Operation direction of throttle channel

i 4-5

Power Indicator:

i 4-1

Bind: Programming a receiver to recognize the code of only one specific transmitter.

i 5-1

Steering Dual Rate:
To be used to adjust steering servo throw.

i 4-4

Throttle Dual Rate:
To be used to adjust throttle throw.

i 4-5

Power Switch:

Battery Installation:

i 3-1

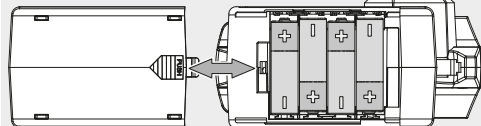

Battery Level Indicator: When the battery level indicator (LED) blinks in red, replace the batteries with new ones immediately.

i 4-1

Steering Trim:
To be used for centering the steering

i 4-4

Throttle Trim:
To be used for centering the throttle.

i 4-5

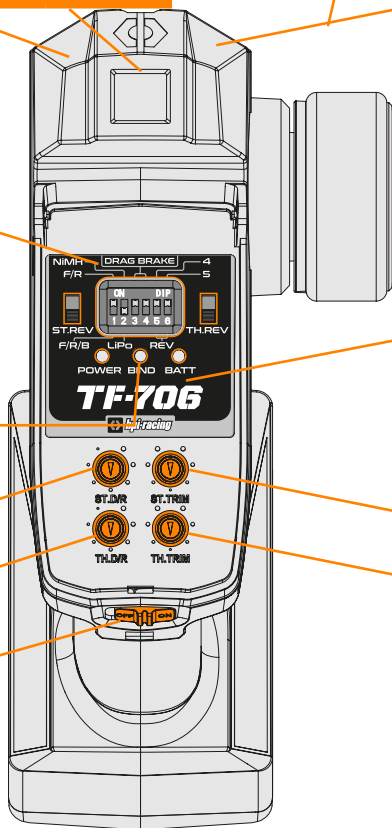

Auxiliary Channels

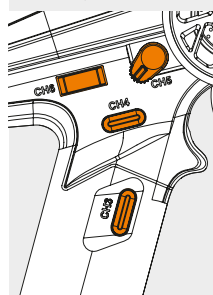

Throttle

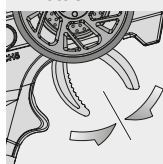

i 3-3

i 6

2 Receiver Connections

2-1 SRL-706 ESC/RX/LED Controller

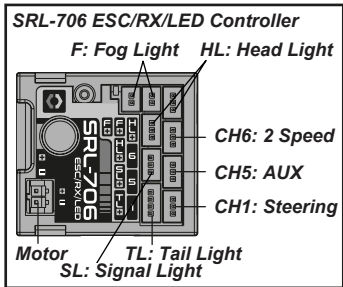
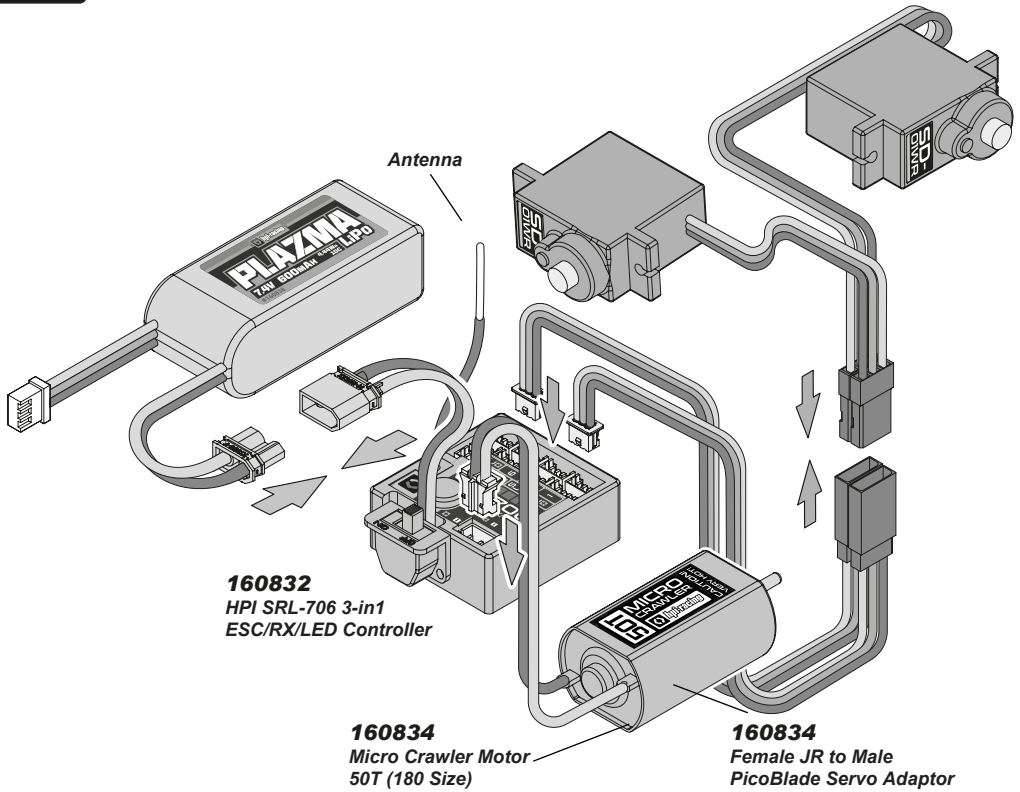

Attention

Do not make sharp bends or cut the antenna.

2-2 RF-706 Receiver & RL-700 Light Controller

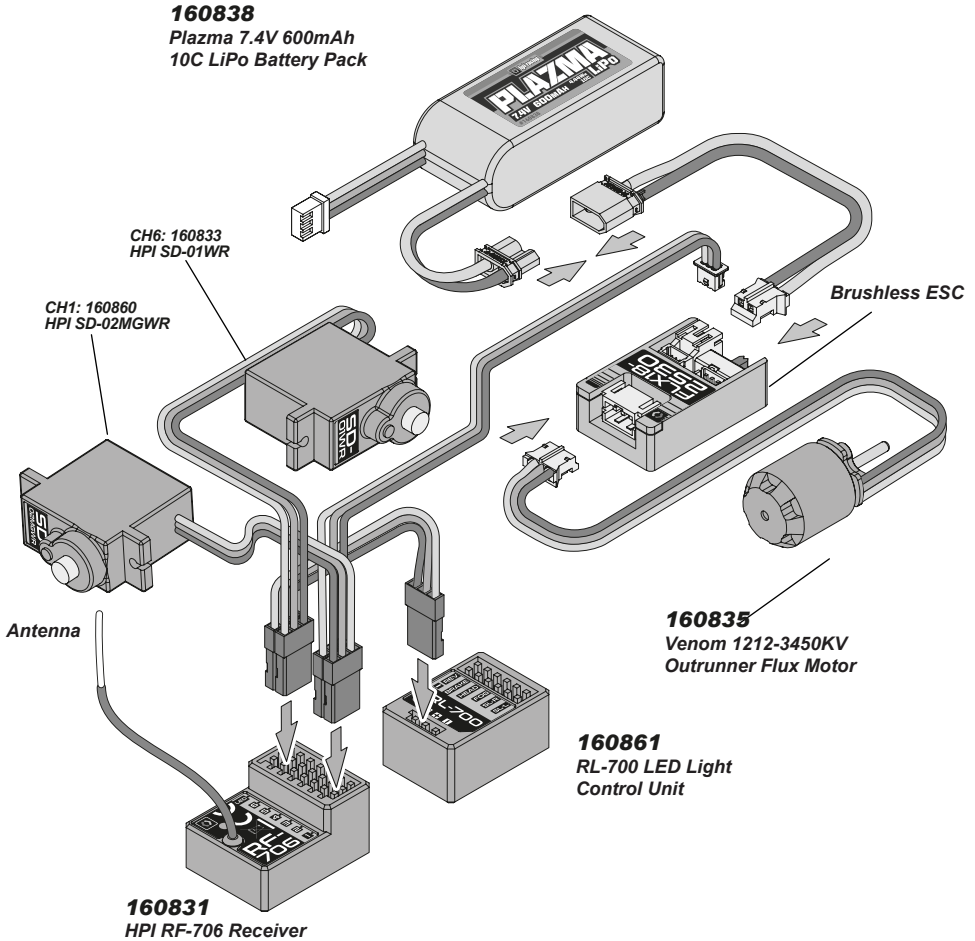

RL-700 Light Controller

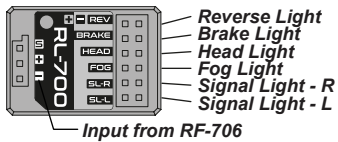

RF-706 Receiver

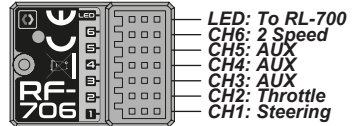

Attention

Do not make sharp bends or cut the antenna.

3 Getting Started

3-1 Transmitter Battery Installation

1 Open battery cover at the bottom of transmitter and install batteries

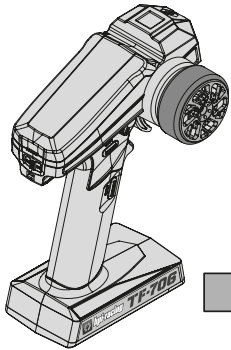

! Do not mix batteries of different ages or types.

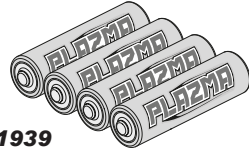

101939
PLAZMA 1.5V Alkaline AA Battery
(Not Included)

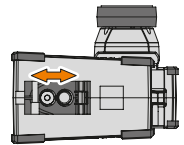
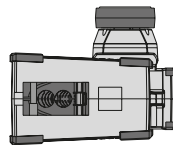
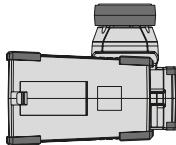
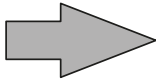

3-2 Transmitter Preparation

1 Check battery level and center throttle trim.

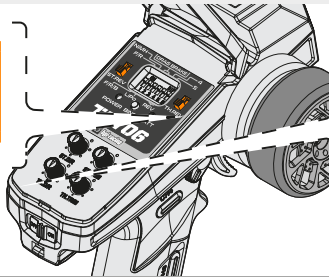

! Centre Throttle Trim



2 Switch on transmitter

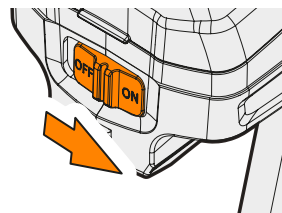
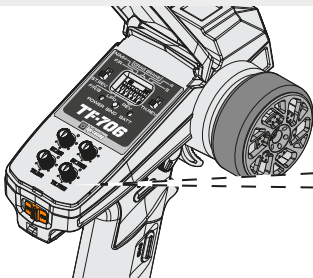

3

Place car on stand, connect battery and turn on receiver

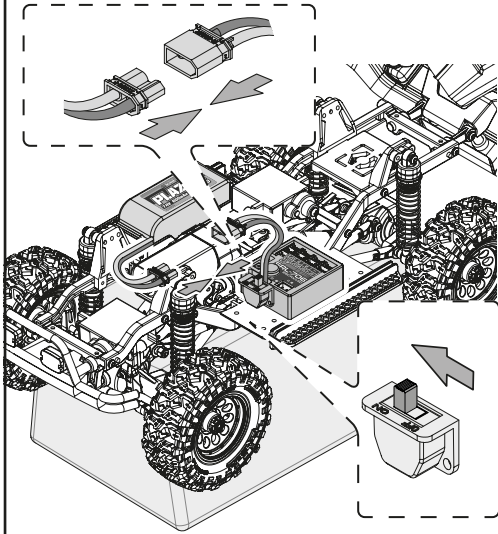

! Do not touch throttle

3-3 Basic Operation

3-3-1 Steering

1 Steering is normally back = left, forward = right. This is adjustable - see transmitter manual for further information.

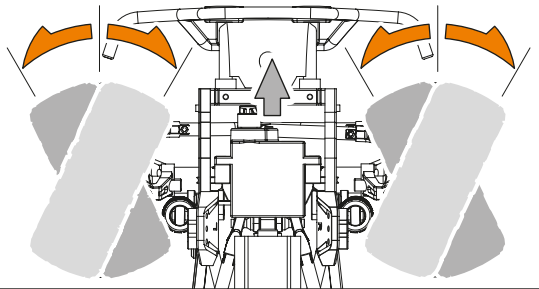
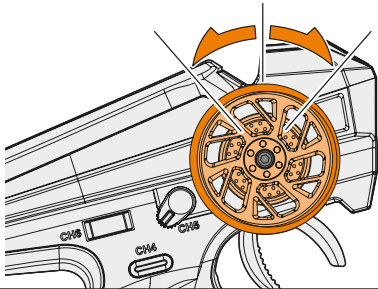

3-3-2 Acceleration

1 Throttle Trigger - neutral position

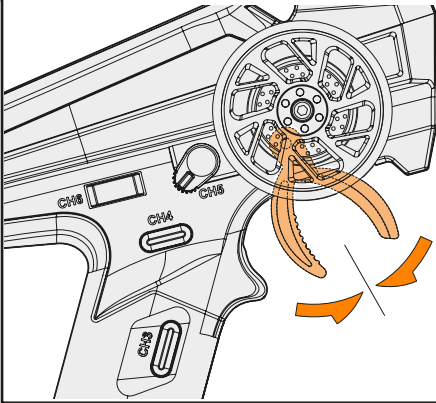

1^A Throttle Trigger - forwards

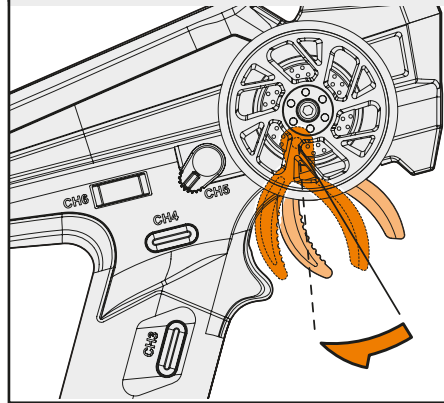

3-3-3 Braking

2 Throttle Trigger - neutral position

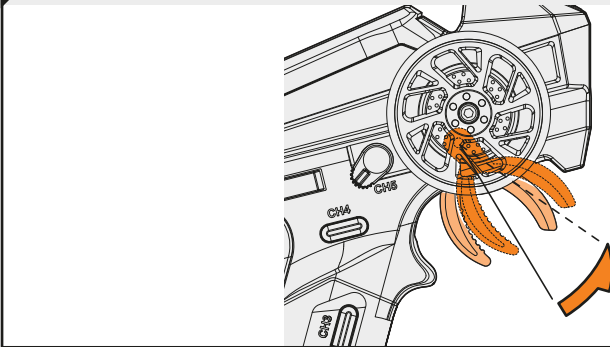

3-4 Checking Radio Range

To properly check the range, have a friend hold the truck and walk to the farthest distance that you plan to operate your model. Operate the controls to make sure the model responds correctly. Do not operate the model if there is any problem with the radio system. If you switch on the R/C car first before the transmitter, you may lose control of the R/C car.



Cautions

2.4GHz radio frequency only functions by line of sight, if you drive behind a solid object or around a corner and lose sight of the vehicle you may lose control of the RC car.

4 Transmitter Functions

4-1 LED Indicator

The POWER LED is used to indicate the functional status of the transmitter, the BATT LED is used to indicate the battery power status of the transmitter and receiver.

In the first 3 seconds after powering on the transmitter, the BATT LED indicates the transmitter battery power status. After 3 seconds, the BATT LED then indicates the receiver battery power status.

When using HPI SRL-706 3-in1 ESC/RX/LED Controller or RF-706 Receiver with a separate receiver battery pack, the BATT LED will display the power level of the car or receiver battery, and change colour according to the battery power status.

When using HPI RF-706 Receiver with an ESC, the BATT LED will display the power level of the BEC Voltage, and should always be Green.

P O W E R L E D	Rapid Flash <i>Schnelles Blinken</i> Flashes rapide 瞬きが早い	Binding Mode <i>Bindungsmodus</i> Mode de liaison バインディングモード
	Slow Flash <i>Langsames Blinken</i> Flashes lent ゆっくり点滅	Transmitter Voltage <i>Senderspannung</i> Tension de l'émetteur 送信機電圧
	Gradual Fade <i>Allmähliches Blinken</i> Flashes progressifs 徐々に点滅	Idle/Sleep Mode <i>Leerlauf-/Schlafmodus</i> Mode veille/inactivité アイドル/スリープモード
	2x Repeating Flash <i>2x Wiederholendes Blinken</i> 2x flashes répétés 2倍の繰り返しフラッシュ	Setup Mode <i>Setup-Modus</i> Mode de configuration セットアップモード

B A T T L E D	Green - ON <i>Grün - AN</i> Vert - ON 緑 - オン	Battery Level - High <i>Batteriestand - Hoch</i> Niveau de batterie - Élevé バッテリーレベル - 高
	Yellow - ON <i>Gelb - AN</i> Jaune - ON 黄色 - オン	Battery Level - Medium <i>Batteriestand - Mittel</i> Niveau de batterie - Moyen バッテリーレベル - 中
	Red - ON <i>Rot - AN</i> Rouge - ON 赤 - オン	Battery Level - Low <i>Batteriestand - Niedrig</i> Niveau de batterie - Faible バッテリーレベル - 低
	Red - Slow Flash <i>Rot - Langsames Blinken</i> Rouge - Flashes lent 赤 - ゆっくり点滅	Battery Level - Ultra Low <i>Batteriestand - Sehr niedrig</i> Niveau de batterie - Très faible バッテリーレベル - 非常に低い

4-2 Bind Button



The bind button is used to bind the transmitter to the car receiver.



4-3 DIP Switches

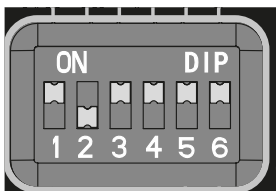

Used for detailed programming with 160832 HPI SRL-706 3-in1 ESC/RX/LED Controller



4-4 Steering Adjustments

4-4-1 Steering Reverse

1 To change direction of steering - e.g for left handed use.

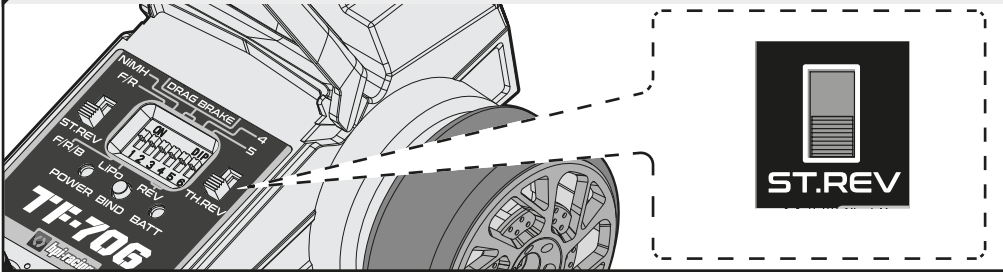

4-4-2 Steering Dual Rate

1 If vehicle is moving without touching the trigger, adjust the Throttle Trigger Trim

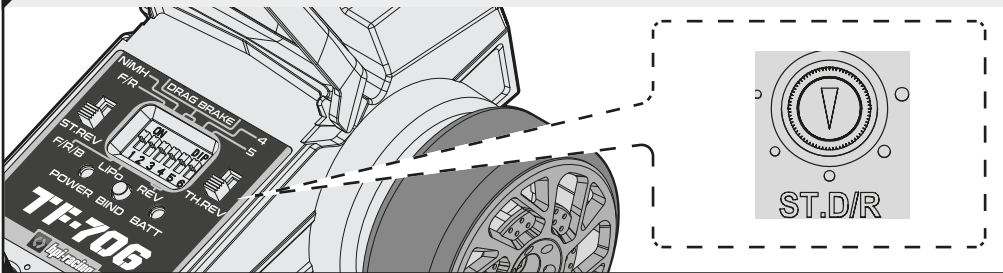

4-4-3 Steering Trim

1 Adjust steering trim until wheels are in correct alignment so that car drives straight

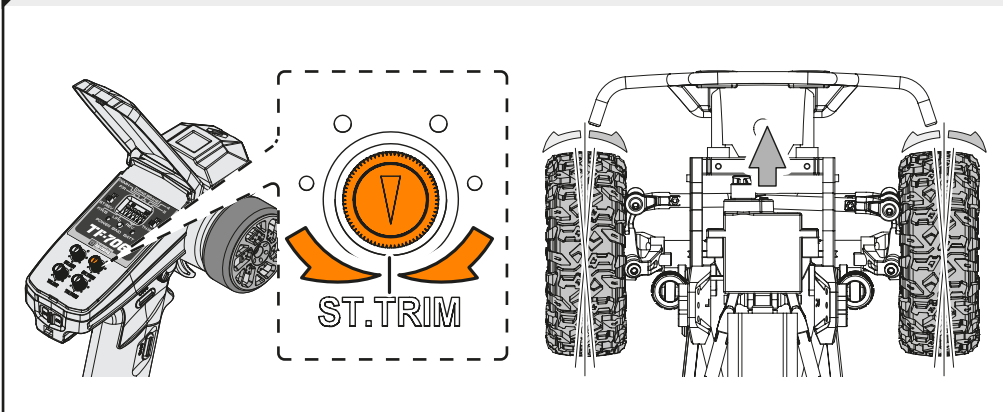

4-5 Throttle Adjustments

4-5-1 Throttle Reverse

1 If vehicle is moving without touching the trigger, adjust the Throttle Trigger Trim

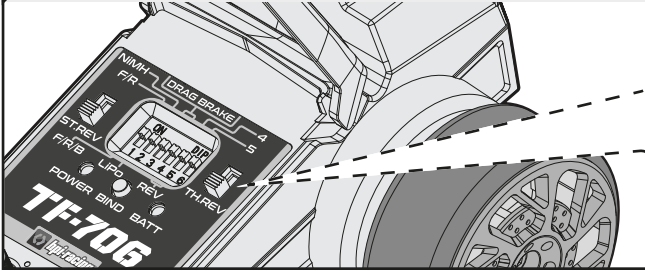

4-5-2 Throttle Dual Rate

1 If vehicle is moving without touching the trigger, adjust the Throttle Trigger Trim

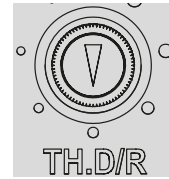
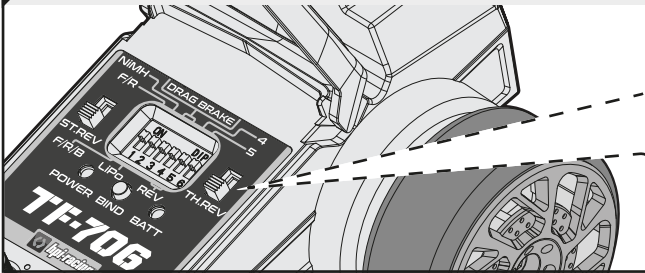

4-5-3 Throttle Trim

1 If vehicle is moving without touching the trigger, adjust the Throttle Trigger Trim

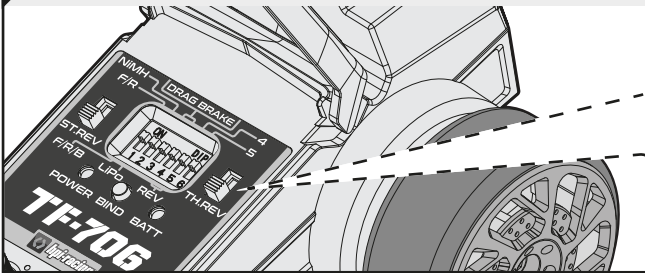

5 Setup/Customisation

5-1 Binding

Programming a receiver to recognize the code of only one specific transmitter. Binding and fail-safe is preset from the factory.



Cautions

Any new binding of transmitter & receiver will clear the preset fail safe.



Cautions

If you change transmitters or add a receiver, you must re-bind before operating your vehicle.

- 1** Place the transmitter and the receiver close to each other (within one meter). Press and hold the transmitter bond button

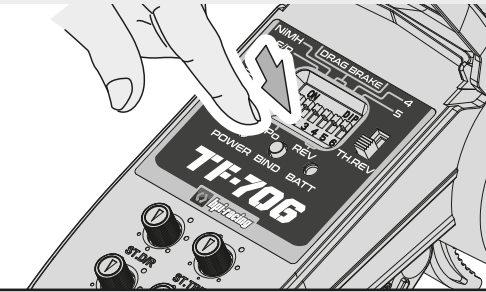

- 2** turn the power switch to the ON position. The Power LED will flash quickly. Release the setup button after 1 second.

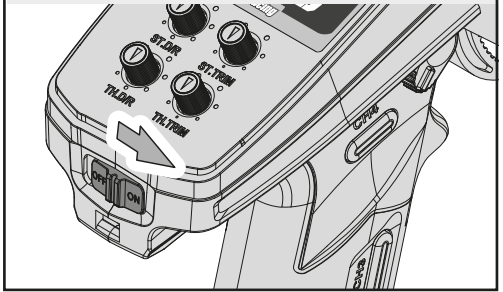

- 3** SRL-706 ESC/RX/LED Controller - Turn the power switch on the Receiver to the ON position. Wait for 1 second. The LED will flash quickly until the connection is established.

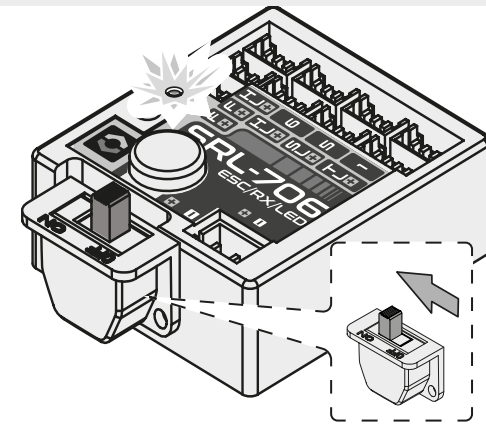

- 4** RF-706 Receiver - Turn the power switch on the Receiver to the ON position. Wait for 1 second. The LED will flash quickly until the connection is established.

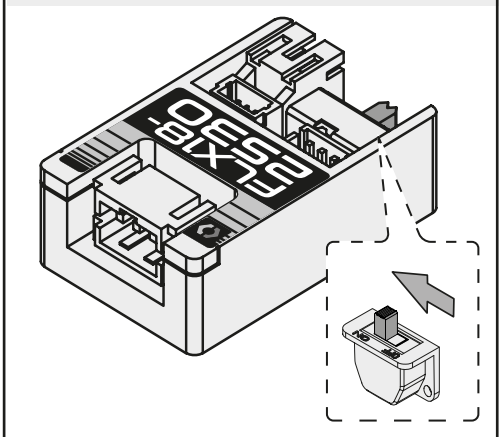

5-2 Fail Safe Setup

This car has a built-in fail safe system that will stop the car if the radio glitches, either because of interference or if the car goes out of range.

The fail safe system has been setup at the factory, but you should become familiar with the function of the fail safe and check the operation before running.

1 Turn on transmitter

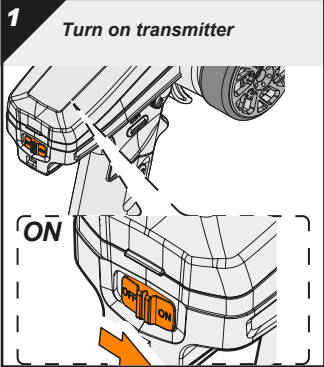

2 Turn on car (receiver)

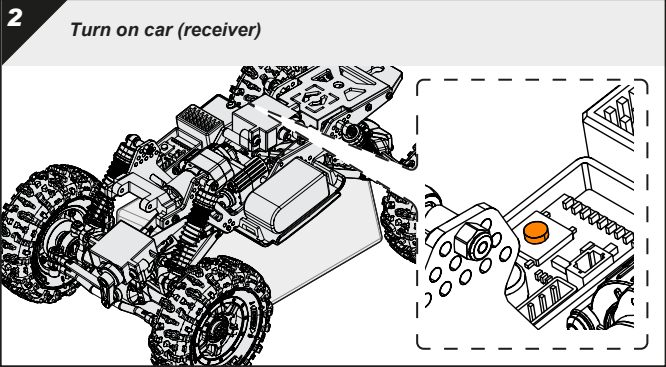

3 Leave throttle trigger in neutral position,

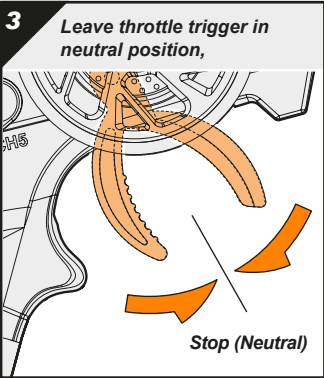

4 Press the setup button and hold it down.

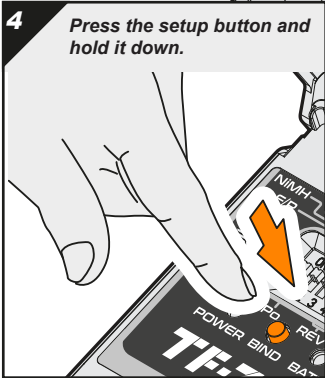

5 To confirm fail safe is working refer to step 7, section 5-1



5-3 Single Hand Operation

The steering wheel of the TF-706 Transmitter can be fitted with a thumb to allow it to be operated using only one hand.

1

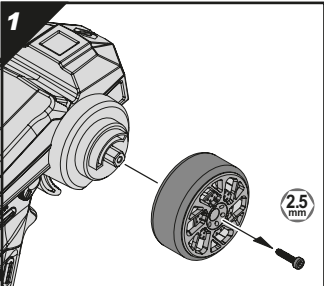

2

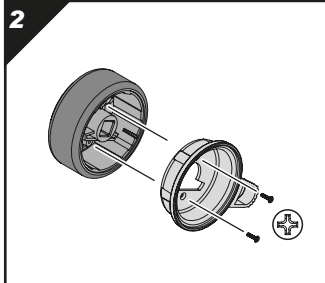

3

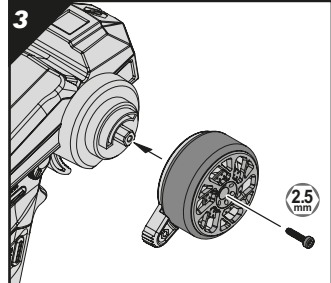

5-4 End point adjustments

End point adjustments (EPA) allow you to set the limits of steering and throttle.

5-4-1 Steering EPA



Cautions

Do not adjust the servo beyond its limit. Damage may occur.

1 Switch on the transmitter

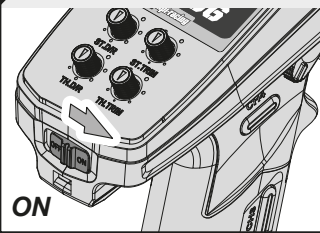

2 Switch on the receiver

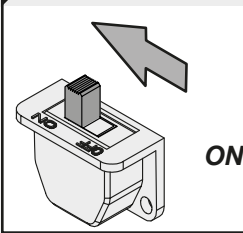

3 Press BIND twice on the transmitter



4

The transmitter will enter the EPA setup mode. The transmitter will beep and the Power LED will flash twice in a repeating pattern to confirm you have entered the EPA setup mode.

5 Rotate the ST.D/R knob clockwise to the appropriate travel point

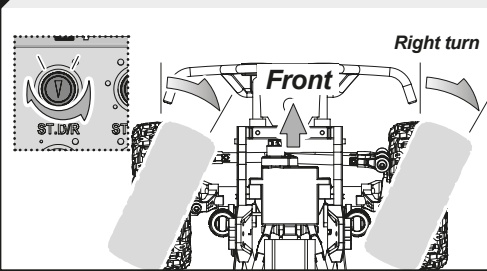

6 Press the BIND button once. The transmitter will now beep once in repeating pattern to confirm the setting has been saved.

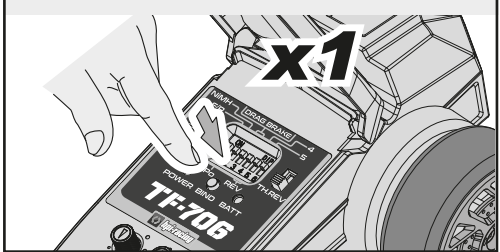

7 Rotate the ST.D/R knob counter-clockwise to the appropriate travel point

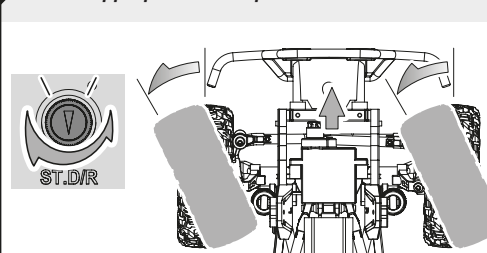

8 Press the BIND button once. The transmitter will now stop beeping to confirm the setting has been saved.

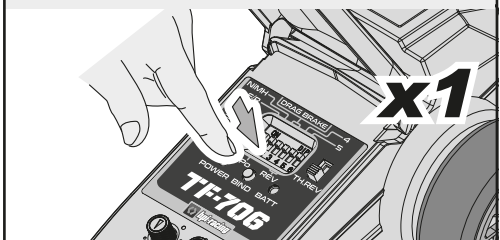

9 Save settings

Press and hold the BIND button on the transmitter for one second to save the settings and exit the EPA setup mode.

The transmitter will sound a long beep and the Power LED will stop flashing and light up continuously.

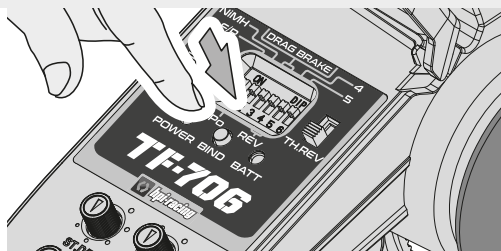

5-4-2 Steering EPA

Repeat process above, but adjust the TH DR knob instead if the ST DR knob.

5-5 Stick Calibration

Use this function to correct for mechanical deviation of the throttle trigger, steering wheel and CH5 knob.

1 First, make sure the CH5 lever is set to the neutral position.

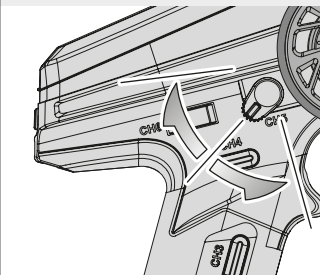

2 Then, turn and hold the steering wheel clockwise to the maximum travel and push and hold the throttle trigger forwards as far as possible.

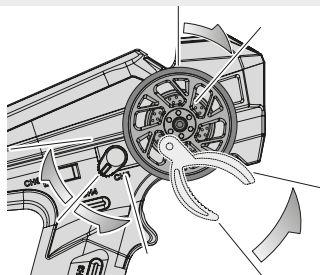

3 Whilst holding this position, turn on the transmitter

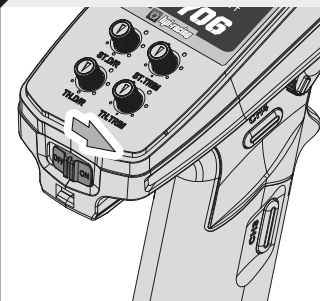

The transmitter will beep 3 times in a repeating pattern to confirm you have entered calibration mode.

4 Set travel

Turn the steering wheel clockwise to the maximum travel, then turn the steering wheel counter clockwise to the maximum travel.

The transmitter will beep 2 times in a repeating pattern to confirm the setting has been saved.

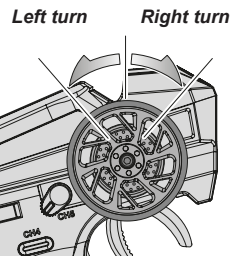

5

Push the throttle trigger forwards as far as possible, then pull the throttle trigger closed as far as possible.

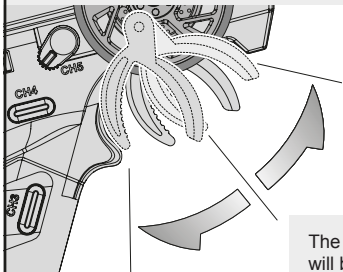

The transmitter will beep once in a repeating pattern to confirm the setting has been saved.

7

Rotate the CH5 lever down as far as possible, then rotate the lever up as far as possible. The transmitter will sound one long beep to confirm the setting has been saved.

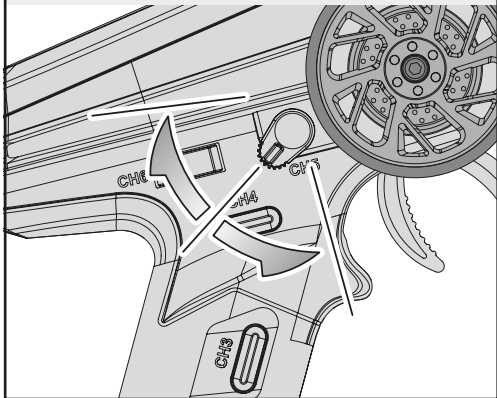

8

Return the CH5 lever to the neutral position.

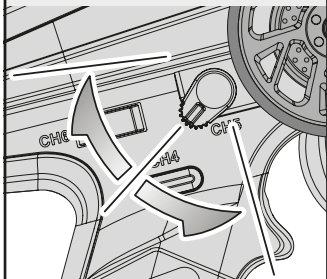

9

Press the BIND button on the transmitter to save the settings.

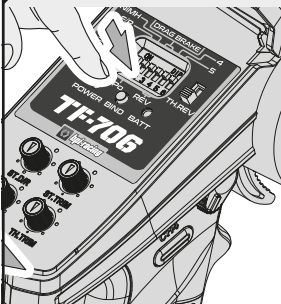

The transmitter will sound a long beep to confirm the settings have been saved.

! If the transmitter does not beep, the calibration process has failed.
● Turn the transmitter off and restart the process to try again.

5-6 Factory Reset

To restore the transmitter to the factory end point settings, please follow the below steps.

1

Press and hold the BIND and CH4 buttons of the transmitter.

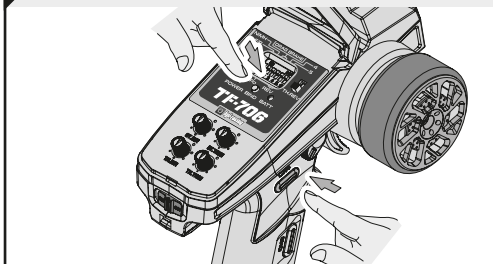

2

Whilst holding this position, turn on the transmitter.

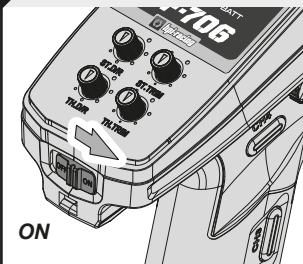

The transmitter will sound one long beep to confirm the factory end point settings have been restored.

ON

6 Extra Controls

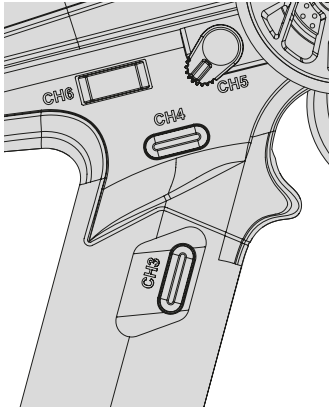

The TF706 also has 4 extra controls - 2 x push buttons (labeled channel 3 and 4) and 2 x 3 way switches (labeled channel 5 and 6).

If your transmitter came bundled with a car, please consult your User Guide for details.

6-6 CH6 EPA

You can also adjust the EPA of CH6.

1 Switch on the transmitter

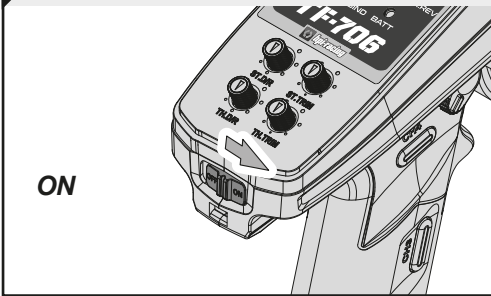

2 Switch on the receiver

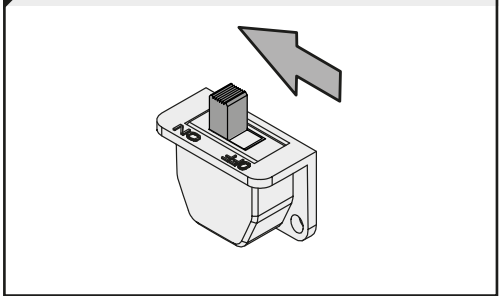

3 Press the BIND twice on the transmitter

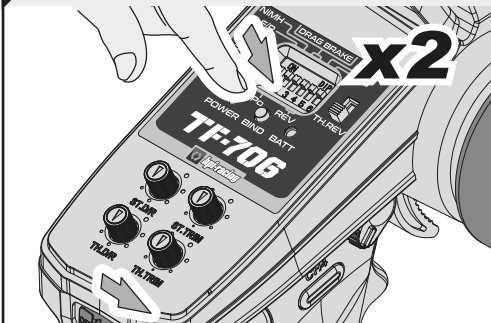

4 Toggle the CH6 3-position Switch to one position.

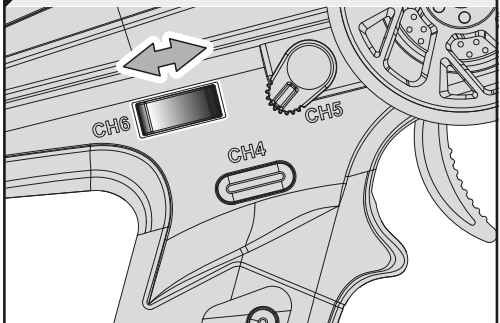

- 5** Rotate the ST.D/R knob to the appropriate travel point

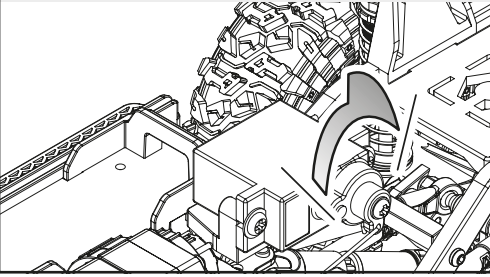

- 6** Press the BIND button once.

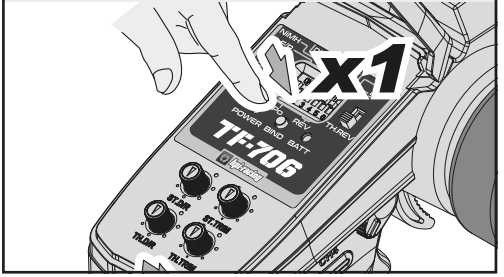

- 7** Toggle the CH6 3-position Switch to the opposite position and repeat step

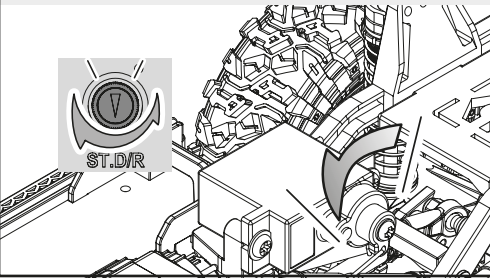

- 8** Press the BIND button once.



- 9** Save settings

Press and hold the BIND button on the transmitter for one second to save the settings and exit the EPA setup mode.

The transmitter will sound a long beep and the Power LED will stop flashing and light up continuously.

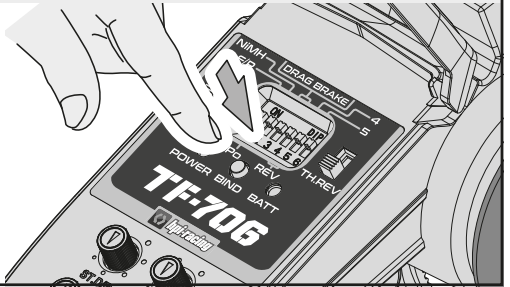

7 DIP switches - SRL-706 Programming

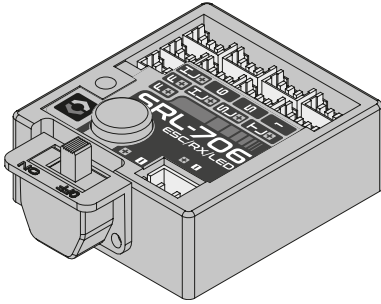

#1 Running Mode

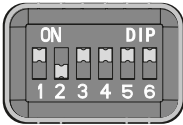

F/R

This mode is used for Rock Crawlers. It will allow instant switching from forward to reverse for quick car control. Please set the Drag Brake Force to 100% if the Rock Crawler mode is used.

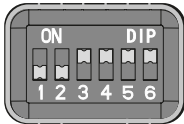

F/R/B

This mode offers Forward, Brake and Reverse. Note, The Reverse function uses a soft start "Double click" function which will only allow reverse to be activated once the motor has stopped moving forward.

#2 LiPo Battery Mode



Cautions

The speed control has 2 types of battery modes to choose from depending on which type of battery you use (NiMH or LiPo).

Setup for the proper battery is needed. If you do not setup your speed control correctly, your battery may explode, swell, smoke, or become useless.



NiMH

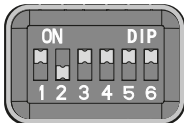

LiPo



Factory setting is LiPo

#3&4 Drag Brake Force

This mode allows the setting of an automatic drag brake when the throttle stick is returned to neutral, simulating the slight braking effect of a brushed motor while coasting. The switches 3 and 4 of the 6-bit DIP switch are used to set the ESC drag brake force.

The drag brake force can be set to 0%, 50%, 75% or 100%.

0%

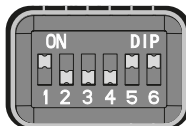

75%

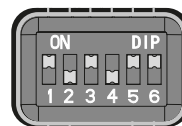

50%

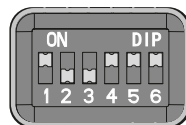

100%

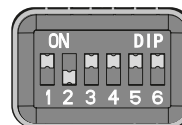

#5&6 Reverse Switch

Switches 5 and 6 of the 6-bit DIP switch are the reverse setting switches of CH4 and CH5, respectively. A switch on the upper position indicates that the servo output is normal; a switch on the lower position indicates that the servo output is reversed.

CH4 and CH5 are not used as standard on the Venture18.

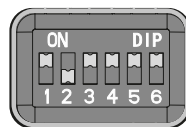

Normal

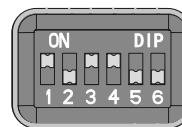

Reversed

7-1-1 Protection Functions

Voltage Protection

Low Voltage Protection: CH2 has no output and LED lights flash slowly

High Voltage Protection: All channels will have no output and LED lights flash fast.

Over Heat Protection

When the internal temperature of the ESC is detected to be too high the ESC will cut off the output power. Stop driving immediately and allow the ESC to cool down for 15 minutes. The Overheat Protection function will turn off and you can drive the R/C car again.

Over Heat Protection: CH2 has no output and LED lights flash fast.

1 Troubleshooting

If RC car does not move or you have no control, see below

Problem	Cause	Remedy	Section
Does Not Move.	Battery is not placed properly in the transmitter.	Place batteries in the transmitter properly.	 SG 1-2-1
	Weak or no battery in model.	Install charged battery.	 SG 1-1 SG 1-3-2
	Damaged motor.	Replace with new motor.	 2-4
	Frayed or broken wiring.	Splice and insulate wiring completely.	 EM 1-1
	ESC is shut down by heat protection circuit.	Stop driving immediately, do not drive the car until the Speed Controller cools down.	 EM 2-3
No Control.	Weak or no batteries in transmitter or model.	Install charged or fresh batteries.	 SG 1-2
	Neutral position or trim is incorrect.	Adjust the steering trim.	 SG 5-1
	Binding Setup is incorrect.	Make sure binding is setup properly.	 SG 2-2 RM 5-1
Steering and Throttle Function Reversed.	Servo reverse switch is in the wrong position.	Set to correct position.	 RM 4-4 RM 4-5
	Wires from ESC to motor are improperly connected.	Re-connect the motor.	 EM 1-1

Specification

8-2 Transmitter

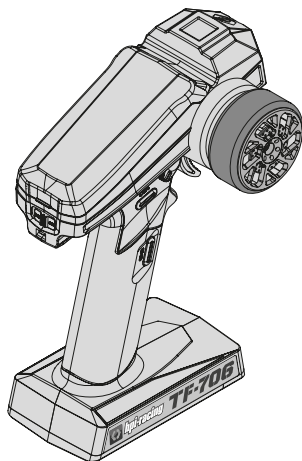

Product Model Produktmodell Modèle de produit 製品モデル	TF-706
Compatible Receivers Kompatible Empfänger Récepteurs compatibles 互換性のある受信機	RF-706 SRL-706
Number of Channels Anzahl der Kanäle Nombre de canaux チャンネル数	6
Frequency Frequenz Fréquence 送信周波数	2.4GHz
Battery Betriebsspannung Piles 電源	AA x 4 2S LiPo
Weight Gewicht Poids 重量	217g

8-2 SRL-706 Receiver

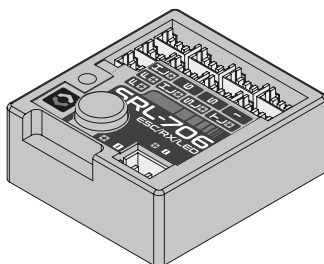

Product Model Produktmodell Modèle de produit 製品モデル	SRL-706
Compatible Transmitters Kompatible Sender Émetteurs compatibles 互換性のある送信機	TF-706
Number of Channels Anzahl der Kanäle Nombre de canaux チャンネル数	6
Frequency Frequenz Fréquence 送信周波数	2.4GHz
Motor Type Motortyp Type de moteur モータータイプ	Brushed 030/050/130/180
Current - Continuous/Burst Dauer-/Stoßstrom Courant continu/en rafale 連続/バースト電流	10A/50A
BEC Output BEC-Ausgang Sortie BEC BEC出力	6V/1A
Operating Voltage Betriebsspannung Tension de fonctionnement 動作電圧	LiPo - 2S NiMH - 5-7Cell
Weight Gewicht Poids 重量	11g

8-3 RF-706 Receiver

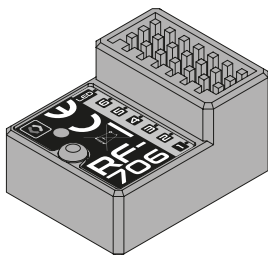

<i>Product Model</i> <i>Produktmodell</i> <i>Modèle de produit</i> 製品モデル	RF-706
<i>Compatible Transmitters</i> <i>Kompatible Sender</i> <i>Émetteurs compatibles</i> 互換性のある送信機	TF-706
<i>Number of Channels</i> <i>Anzahl der Kanäle</i> <i>Nombre de canaux</i> チャンネル数	6
<i>Frequency</i> <i>Frequenz</i> <i>Fréquence</i> 送信周波数	2.4GHz
<i>Operating Voltage</i> <i>Betriebsspannung</i> <i>Tension de fonctionnement</i> 動作電圧	3.5 ~ 8.4V/DC
<i>Weight</i> <i>Gewicht</i> <i>Poids</i> 重量	7.7g

8-4 RL-700 LED Light Control Unit

The HPI RL-700 LED Light Control Unit allows you control up to 6 sets of LED lights with any HPI RF-700 series receiver.

The LED light modes function the same way as with the HPI SRL-706 3-in-1 ESC/RX/LED Controller. Press the CH3 button on the transmitter to switch between the different LED light modes.

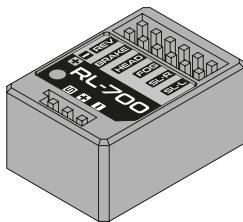

<i>Product Model</i> <i>Produktmodell</i> <i>Modèle de produit</i> 製品モデル	RL-700
<i>Compatible Receivers</i> <i>Kompatible Empfänger</i> <i>Récepteurs compatibles</i> 互換性のある受信機	RF-700 Series
<i>Operating Voltage</i> <i>Betriebsspannung</i> <i>Tension de fonctionnement</i> 動作電圧	3.5 ~ 8.4V/DC
<i>Weight</i> <i>Gewicht</i> <i>Poids</i> 重量	4.2g

FCC COMPLIANCE STATEMENT

This device transmits in the range 2.4 to 2.4835 GHz and has been tested to comply with the limits for a Part 15 Class B device of the FCC rules. These limits are designed to provide reasonable protection against harmful interference in a residential installation. This equipment generates, uses and can radiate radio frequency energy and, if not installed and used in accordance with the instructions, may cause harmful interference to radio communications. Any change or modification to the device not expressly approved by the manufacturer may void the user's authority to operate the equipment. Operation is subject to the following two conditions:

(1) This device may not cause harmful interference, and (2) This device must accept any interference received, including interference that may cause undesired operation.

Canada Compliance Statement:

This Class B digital apparatus complies with Canadian ICES-003. (Cet appareil numérique de la classe B est conforme à la norme NMB-003 du Canada.) This equipment complies with the FCC/IC radiation exposure limits set forth for FCC and Industry Canada portable transmitting devices operation in an uncontrolled environment. The equipment should only be used or installed at locations where there is normally at least a 20cm separation between the antenna and all persons. This transmitter must not be co-located or operated in conjunction with any other antenna or transmitter.

CE Compliance statement



The radio equipment type in this product transmits in the frequency range 2.4 to 2.4835 GHz with a maximum power of 18dBm and is in compliance with EU Directive 2014/53/EU. The full text of the Declaration of Conformity is available at www.hpiracing.com/ce

Die Fernsteuerung in diesem Produkt überträgt in dem Frequenzbereich 2.4 bis 2.4835 GHz mit einer maximalen Stärke von 18dBm und sie ist in Übereinstimmung mit der EU Richtlinie 2014/53/EU. Der volle Text und die Erklärungen zur Konformität finden Sie unter www.hpiracing.com/ce

Cet appareil transmet dans la gamme de fréquence de 2,4 à 2.4835 GHz avec une puissance de 18dBm et est conforme à la Directive UE 2014/53 / UE.

Le texte intégral de la Déclaration de conformité est disponible sur www.hpiracing.com/ce

El tipo de equipo de radio en este producto transmite en el rango de frecuencia de 2.4 a 2.4835 GHz con una potencia máxima de 18dBm y cumple con la Directiva de la UE 2014/53/UE. El texto completo de la Declaración de conformidad está disponible en www.hpiracing.com/ce



www.hpiracing.com

HPI RACING A/S
Jegindavej 21
DK-8800 Viborg

info@hpiracing.com