

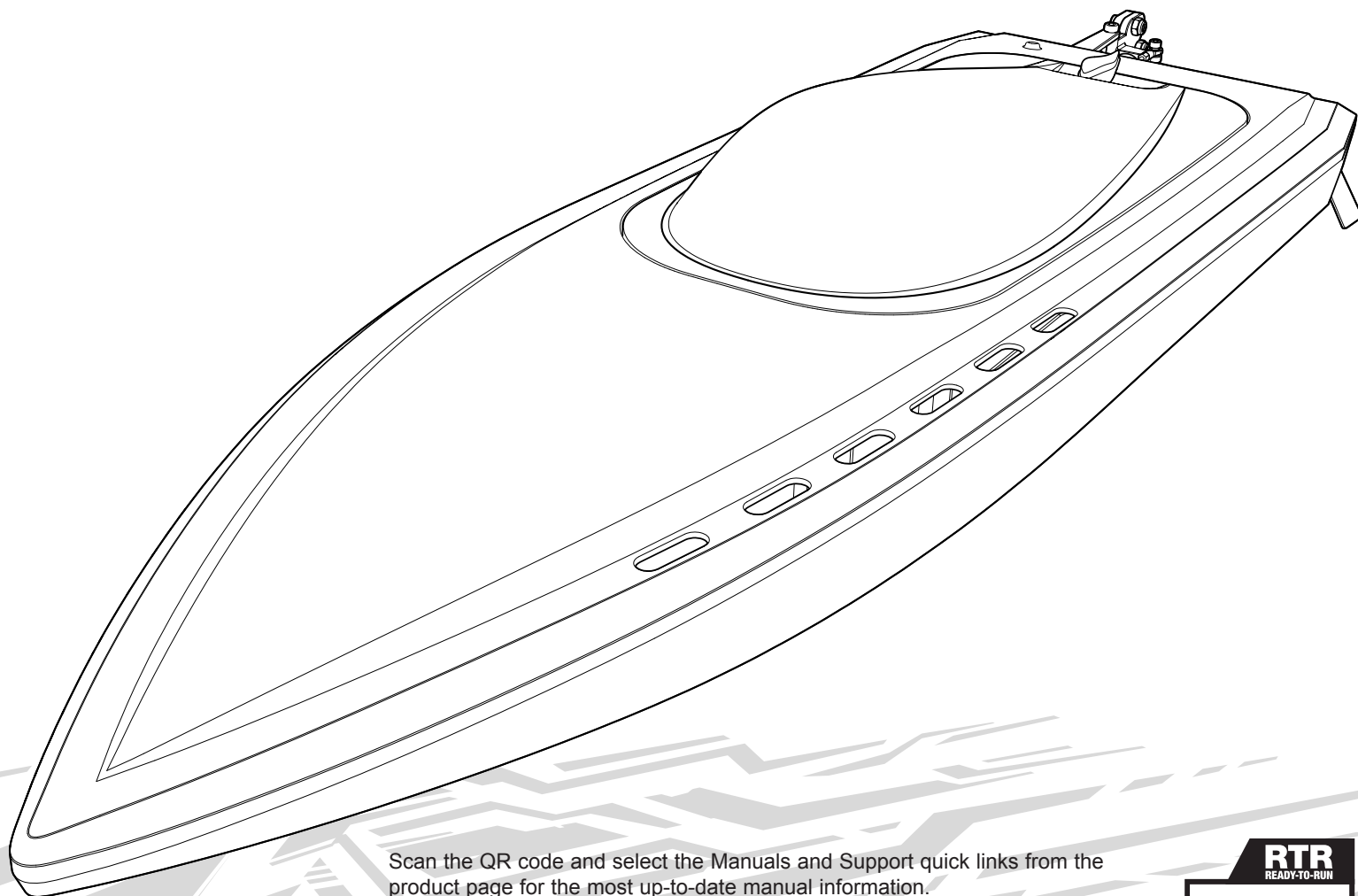

SONICWAKE 24

24" SELF-RIGHTING BRUSHLESS DEEP V RTR



Scan the QR code and select the Manuals and Support quick links from the product page for the most up-to-date manual information.

Scannen Sie den QR-Code und wählen Sie auf der Produktseite die Quicklinks Handbücher und Unterstützung, um die aktuellsten Informationen zu Handbücher.

Scannez le code QR et sélectionnez les liens rapides Manuals and Support sur la page du produit pour obtenir les informations les plus récentes sur le manuel.

Scannerizzare il codice QR e selezionare i Link veloci Manuali e Supporto dalla pagina del prodotto per le informazioni manuali più aggiornate.



PRB-1992

Owners Manual • Bedienungsanleitung
Manuel de l'utilisateur • Manuale dell'utente

1097855

Created: 04/2025

HORIZON
H O B B Y

NOTICE

All instructions, warranties and other collateral documents are subject to change at the sole discretion of Horizon Hobby, LLC. For up-to-date product literature, visit www.horizonhobby.com or www.towerhobbies.com and click on the support or resources tab for this product.

MEANING OF SPECIAL LANGUAGE

The following terms are used throughout the product literature to indicate various levels of potential harm when operating this product:

WARNING: Procedures, which if not properly followed, create the probability of property damage, collateral damage, and serious injury OR create a high probability of superficial injury.

CAUTION: Procedures, which if not properly followed, create the probability of physical property damage AND a possibility of serious injury.

NOTICE: Procedures, which if not properly followed, create a possibility of physical property damage AND little or no possibility of injury.

 **WARNING:** Read the ENTIRE instruction manual to become familiar with the features of the product before operating. Failure to operate the product correctly can result in damage to the product, personal property and cause serious injury.

This is a sophisticated hobby product and NOT a toy. It must be operated with caution and common sense and requires some basic mechanical ability. Failure to operate this Product in a safe and responsible manner could result in injury or damage to the product or other property. This product is not intended for use by children without direct adult supervision. Do not use with incompatible components or alter this product in any way outside of the instructions provided by Horizon Hobby, LLC. This manual contains instructions for safety, operation and maintenance. It is essential to read and follow all the instructions and warnings in the manual, prior to assembly, setup or use, in order to operate correctly and avoid damage or serious injury.

Age Recommendation: Not for children under 14 years. This is not a toy.

Safety Precautions and Warnings

As the user of this product, you are solely responsible for operating in a manner that does not endanger yourself and others or result in damage to the product or the property of others.

- When handling and/or transporting your boat, always pick up the boat from the front, keeping all moving parts pointed away from you.
- Always keep a safe distance in all directions around your model to avoid collisions or injury. This model is controlled by a radio signal subject to interference from many sources outside your control. Interference can cause momentary loss of control.
- Always operate your model in open spaces away from full-size vehicles, traffic and people.
- Always carefully follow the directions and warnings for this and any optional support equipment (chargers, rechargeable battery packs, etc.).
- Always keep all chemicals, small parts and anything electrical out of the reach of children.
- Always avoid water exposure to all equipment not specifically designed and protected for this purpose. Moisture causes damage to unprotected electronics.
- Never place any portion of the model in your mouth as it could cause serious injury or even death.
- Never operate your model with low transmitter batteries.

Water-Resistant Boat with Waterproof Electronics

Your new Horizon Hobby boat has been designed and built with a combination of waterproof and water-resistant components to allow you to operate the product in calm, fresh water conditions.

While the entire boat is highly water-resistant, it is not completely waterproof and your boat should NOT be treated like a submarine. The various electronic components used in the boat, such as the ESC, servo(s) and receiver are waterproof, however, most of the mechanical components are water-resistant and require additional maintenance after use.

Metal parts, including the bearings, pins, screws and nuts, propeller, rudder, rudder mounts, propeller struts, as well as the contacts in the electrical cables, will be susceptible to corrosion if additional maintenance is not performed after running in wet conditions. To maximize the long-term performance of your boat and to keep the warranty intact, the procedures described in the **Wet Conditions Maintenance** section must be performed regularly.

 **CAUTION:** Failure to exercise caution while using this product and complying with the following precautions could result in product malfunction and/or void the warranty.

General Precautions

- Read the **Wet Conditions Maintenance** procedures and make sure that you have all the tools you will need to properly maintain your boat.
- Not all batteries can be used in wet conditions. Consult the battery manufacturer before use. Caution should be taken when using LiPo batteries in wet conditions.

- Most transmitters are not water-resistant. Consult your transmitter's manual or the manufacturer before operation.
- Never operate your transmitter or boat when lightning is present.
- Salt water is very conductive and highly corrosive. If you choose to run your boat in salt water, immediately rinse the boat in fresh water after each use. Operating your boat in salt water is at the sole discretion of the modeler.

Wet Conditions Maintenance

- Drain any water that has collected in the hull by removing the drain plug or canopy and tilting the boat in the appropriate direction to drain the water.

 **CAUTION:** Always keep hands, fingers, tools and any loose or hanging objects away from rotating parts.

- Remove the battery pack(s) and dry the contacts. If you have an air compressor or a can of compressed air, blow out any water that may be inside the recessed connector housings.
- Remove all moving parts. Dry and lubricate parts after every 30 minutes of operation or if the boat becomes submerged.

NOTICE: Never use a pressure washer to clean your boat.

- Use an air compressor or a can of compressed air to dry the boat and help remove any water that may have gotten into small crevices or corners.
- Spray the bearings, fasteners and other metal parts with a water-displacing light oil or lubricant.
- Let the boat air dry before you store it. Water (and oil) may continue to drip for a few hours.

Table of Contents

Safety Precautions and Warnings.....	2	Boating Tips	9
Water-Resistant Boat with Waterproof Electronics	3	When You Are Finished	9
Box Contents.....	4	Maintenance.....	10
Specifications	4	Replacement Parts.....	12
Charging Warnings.....	5	Optional Parts.....	12
Charge the Vehicle Battery	5	Hardware	13
Install the Transmitter Batteries	6	Troubleshooting Guide	13
Transmitter Functions.....	6	2-Year Limited Warranty	14
Failsafe	6	Warranty and Service Contact Information	15
Binding.....	7	FCC Information	16
Install the Vehicle Battery.....	7	IC Information.....	16
Range Check.....	8	Compliance Information for the European Union.....	16
Low Voltage Cutoff (LVC)	8	Exploded View.....	62

Box Contents

- Spektrum® SLT2 2-Channel Transmitter (SPMRSLT200)
- Spektrum® 11.1V 3200mAh 3S 30C Smart LiPo Battery: IC3 (SPMX32003S30)
- Spektrum® S120 USB-C Smart Charger 1x20W (SPMXC1020)
- Servo 5.3kg: 4.8–6v Waterproof Analog (PRB18039)
- Firma™ 3542 2500Kv Outrunner Marine Motor: 3.175mm (SPMXMM1600)
- Spektrum® Marine 50A Brushless ESC (SPMX-1128)
- Spektrum® SR215 DSMR 2-Channel Receiver (SPMSR215)
- (4) AA Alkaline Transmitter Batteries
- ABS Display Stand

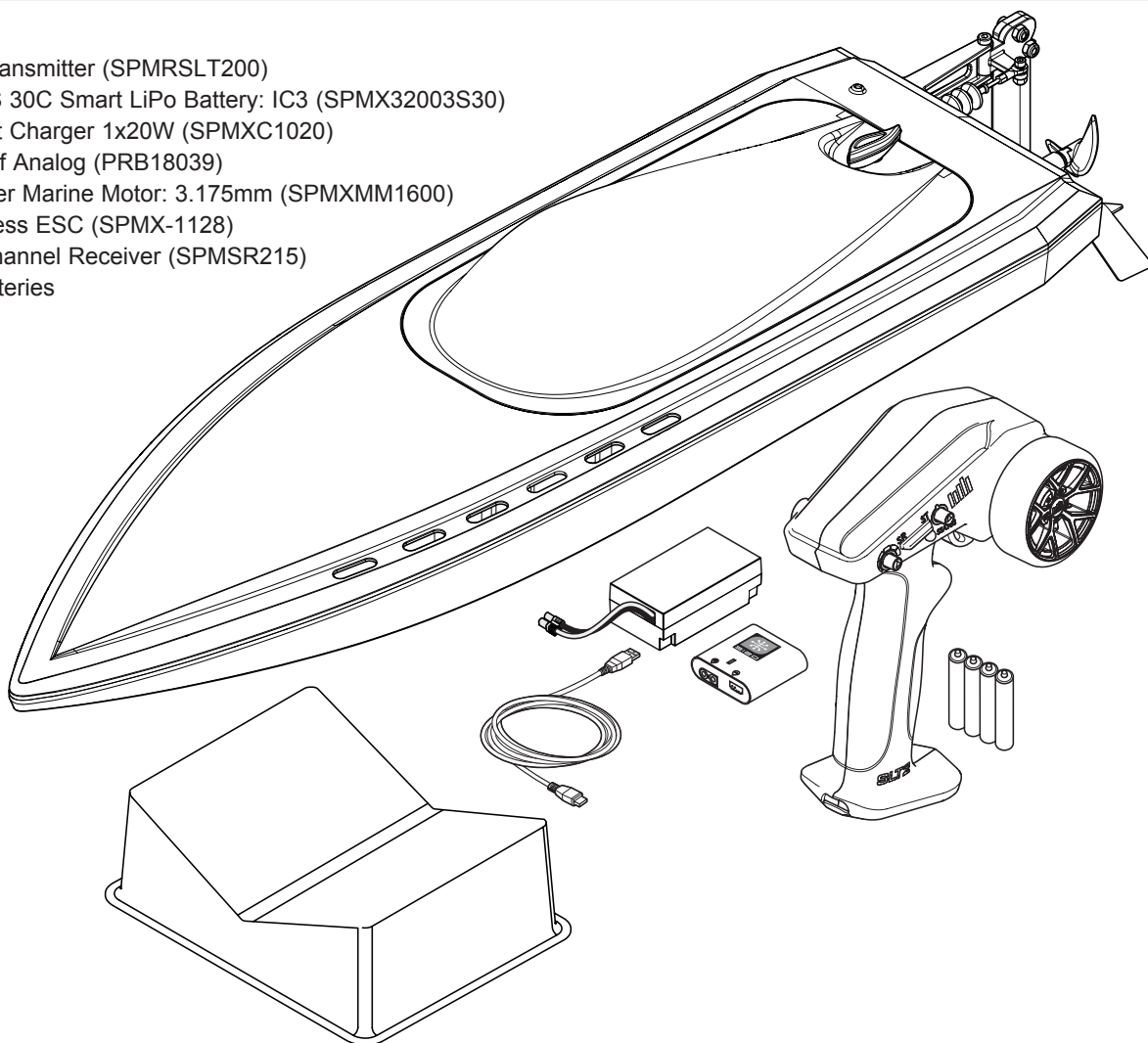

Specifications

4.3 in.
(109mm)

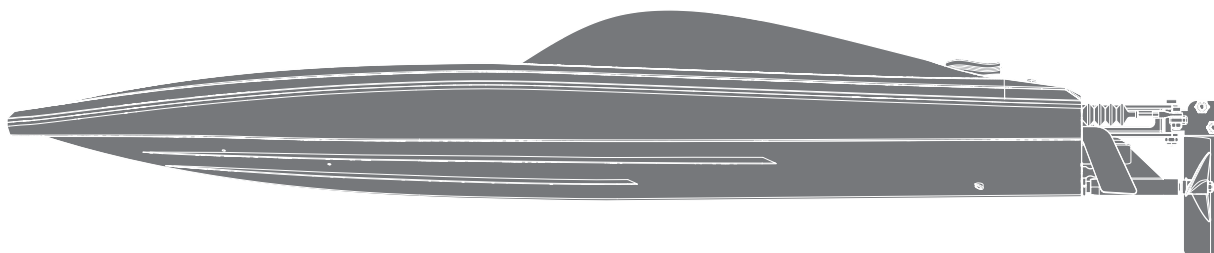

7.1 in.
(180mm)

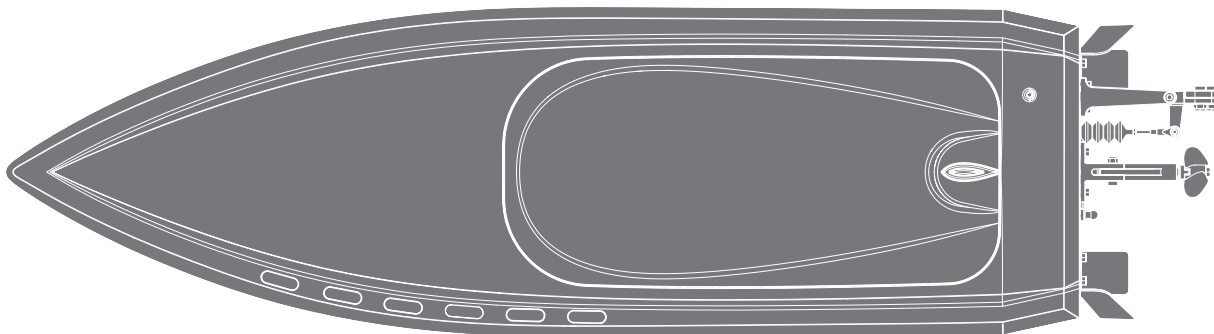

24.0 in. (609mm)

Charging Warnings

WARNING: Failure to exercise caution while using this product and comply with the following warnings could result in product malfunction, electrical issues, excessive heat, FIRE, and ultimately injury and property damage.

- **NEVER LEAVE CHARGING BATTERIES UNATTENDED.**
- **NEVER CHARGE BATTERIES OVERNIGHT.**
- Never attempt to charge dead, damaged or wet battery packs.
- Never attempt to charge a battery pack containing different types of batteries.
- Never allow children under 14 years of age to charge battery packs.
- Never charge batteries in extremely hot or cold places or place in direct sunlight.
- Never charge a battery if the cable has been pinched or shorted.
- Never connect the charger if the power cable has been pinched or shorted.
- Never attempt to dismantle the charger or use a damaged charger.
- Always use only rechargeable batteries designed for use with this type of charger.
- Always inspect the battery before charging.
- Always keep the battery away from any material that could be affected by heat.
- Always monitor the charging area and have a fire extinguisher available at all times.

- Always end the charging process if the battery becomes hot to the touch or starts to change form (swell) during the charge process.
- Always connect the positive leads (+) and negative leads (-) correctly.
- Always disconnect the battery after charging, and let the charger cool between charges.
- Always charge in a well-ventilated area.
- Always terminate all processes and contact Horizon Hobby if the product malfunctions.
- Charge only rechargeable batteries. Charging non-rechargeable batteries may cause the batteries to burst, resulting in injury to persons and/or damage to property.
- The USB outlet shall be installed near the equipment and shall be easily accessible.

CAUTION: Always ensure the battery you are charging meets the specifications of this charger. Not doing so can result in excessive heat and other related product malfunctions, which can lead to user injury or property damage.

CAUTION: If at any time during the charging process the battery pack becomes hot or begins to puff, disconnect the battery immediately and discontinue the charge process as batteries can cause fire, collateral damage and injuries.

Charge the Vehicle Battery

Follow the manufacturer's directions for your charger to properly charge the vehicle battery.

CAUTION: Only use chargers designed to charge the chosen battery type. Using an incorrect charger or incorrect charger settings could cause the battery to catch fire or explode.

Operating the Included S120 Smart Charger

1. Connect the S120 charger to a USB power supply adapter. We recommend connecting with the 65W Spektrum power supply (SPMX-1027).
2. Connect the IC3 connector to the charge port on the S120 charger.

TIP: The battery can be disconnected from the charger at any time to stop the charging process.

3. Refer to the LED Indicator table for charger status.
4. A red LED illuminates to indicate abnormal charging. Follow the operation steps to ensure proper connection is used to charge the battery.

IMPORTANT: Non-Smart batteries will cause the LED to illuminate red and the S120 will not recognize or charge the battery.

LED INDICATOR

Power On – No Battery Connected	USB 5V/1A, 5V/2A: White LED USB Quick Charge 2.0/3.0: Blue LED	
LiPo 2S and 3S Spektrum Smart Battery	Battery Capacity	Purple LED
	Less Than 25%	Single Flash
	25% – 75%	Double Flash
	76% – 99%	Triple Flash
Charge Complete	Green LED (Solid)	
Firmware Update	Red-Green-Blue Flashing LED	
Error	Red LED (Solid)	

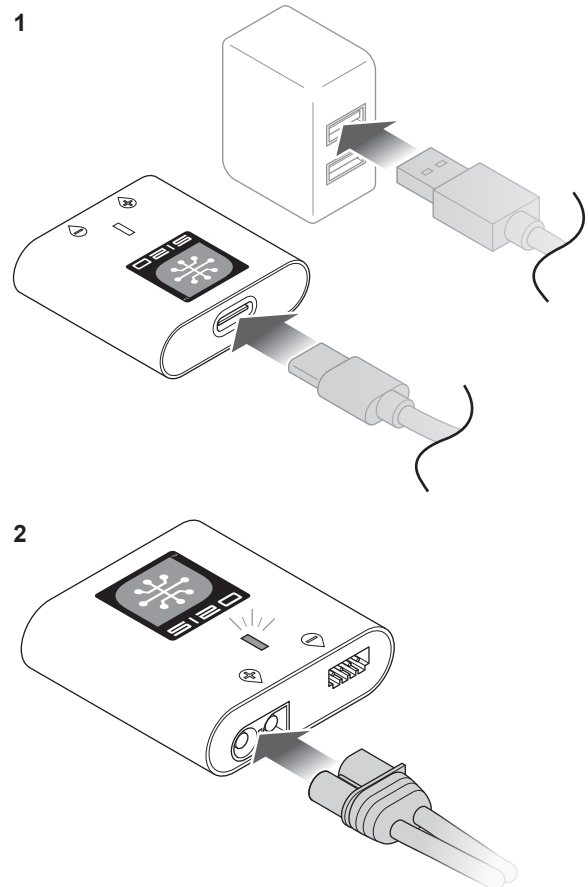

Install the Transmitter Batteries

This transmitter requires 4 AA batteries.

1. Remove the battery cover from the transmitter.
2. Install the batteries as shown.
3. Install the battery cover.

CAUTION: NEVER remove the transmitter batteries while the model is powered ON. Loss of model control, damage, or injury may occur.

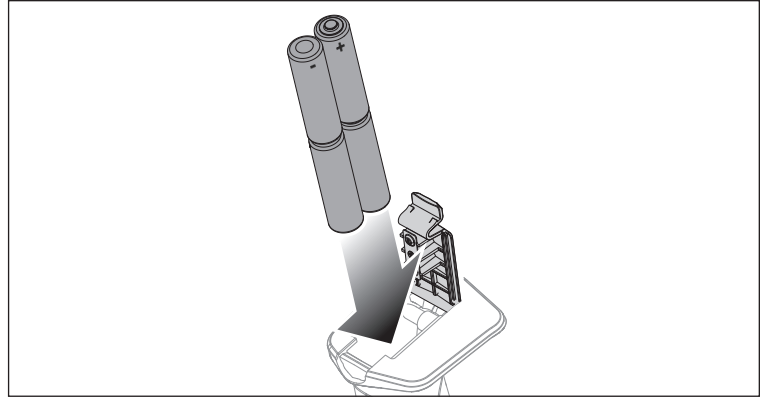

Transmitter Functions

1. **Steering Wheel** Controls direction (left/right) of the model
2. **Throttle Trigger** Controls speed and direction (forward/brake/reverse) of the model
3. **Power Button** Turns the power on/off
4. **Steering (ST-R)** Servo Reversing Reverses the steering channel
5. **Throttle Limit** Limits throttle output to 50/75/100%
Select 50% or 75% for less experienced drivers or when you are driving the vehicle in a small area
6. **Indicator Lights**—Indicates radio connectivity and adequate battery power
Flashing Red Light—Indicates the battery voltage is critically low. Replace the batteries
7. **Steering Rate** Adjusts the steering end points
8. **Steering Trim** Adjusts the steering center point

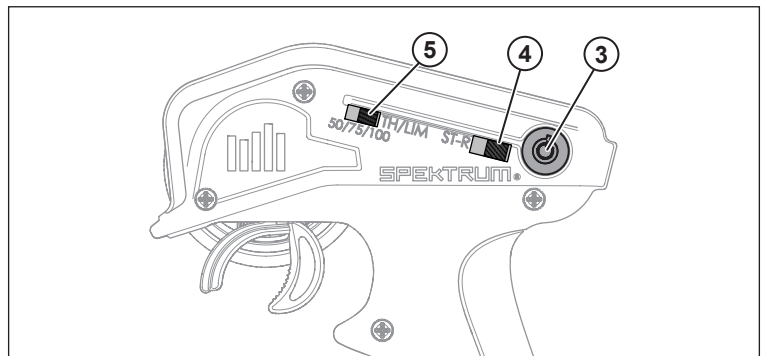
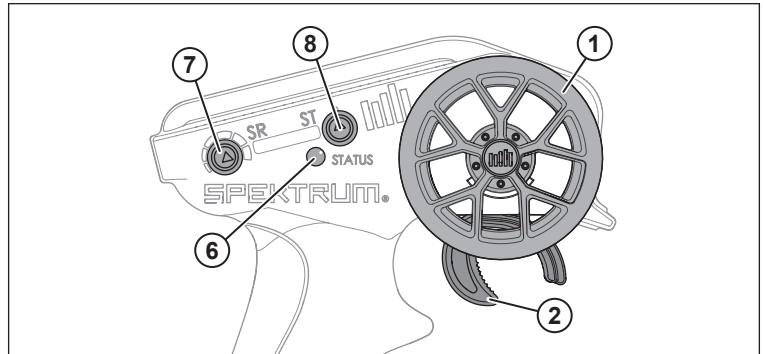

Failsafe

In the unlikely event that the radio connection is lost during use, the receiver will drive the servo and ESC to their pre-programmed failsafe positions (normally no throttle and straight steering).

If the receiver is powered on before powering on the transmitter, the receiver will enter this failsafe mode. When the transmitter is powered on, normal control is resumed.

Binding

The transmitter and receiver are bound at the factory.

Binding is the process of programming the receiver to recognize the GUID (Globally Unique Identifier) code of a single specific transmitter.

If you need to rebind, follow the instructions below:

1. Connect a fully charged battery to the IC3 connector.
2. Press the bind button 3 times quickly (within 1.5 seconds of the first button press).
The receiver LED flashes rapidly with a pause.
3. Set the trims and control positions at the desired failsafe settings, and power ON the SLT2 transmitter.
4. When the SLT2 transmitter LED and the receiver LED remain lit, binding is complete.

You must rebind when binding the receiver to a different transmitter.

NOTICE: Do not attempt to bind the transmitter and receiver if there are other compatible transmitters in bind mode within 400 feet. Doing so may result in unexpected binding.

IMPORTANT: When using a Smart ESC and Smart battery, the transmitter Smart Battery Level indicator displays the vehicle battery level within 10 seconds of powering on and binding.

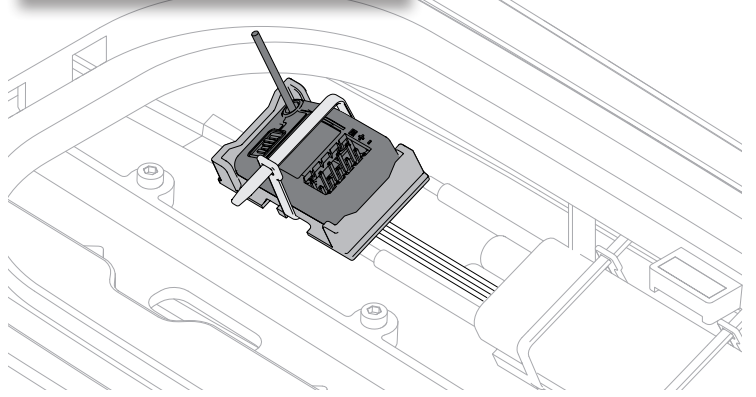
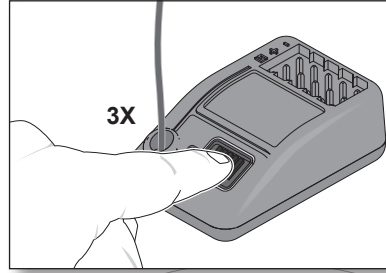

Install the Vehicle Battery

1. Power on the transmitter.
2. Set the Sonicwake on the included display stand.
3. Rotate the hatch lock 90 degrees.
4. Lift the hatch off the hull.
5. Lift the locking ring of the battery tray to remove the tray from the battery base.
6. Install the recommended, fully charged battery into the tray, and secure it using the included hook and loop straps.
7. Place the tray into the battery base, and slide it forward until the tray locks to the base.
8. Connect the IC3 battery lead to the ESC IC3 connector.
9. Replace the hatch cover, and rotate the hatch lock to secure the hatch.

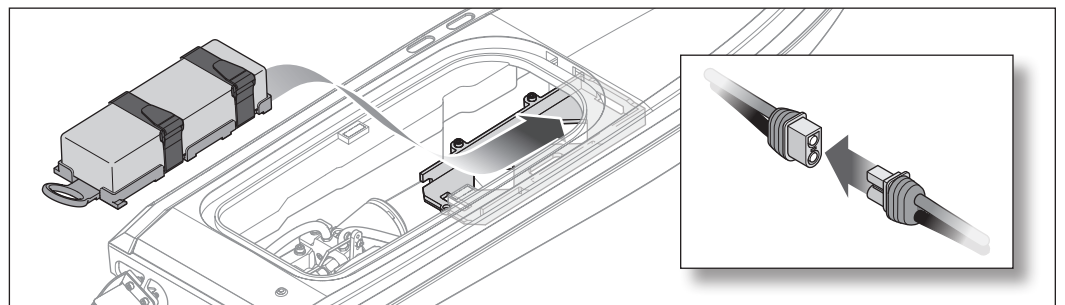
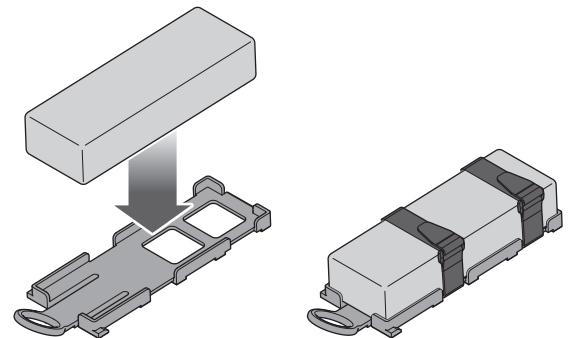
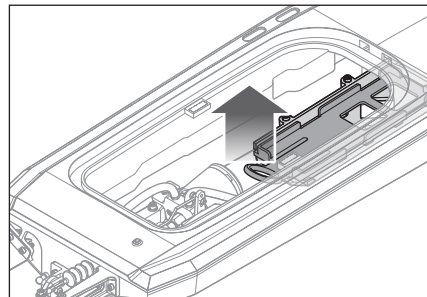
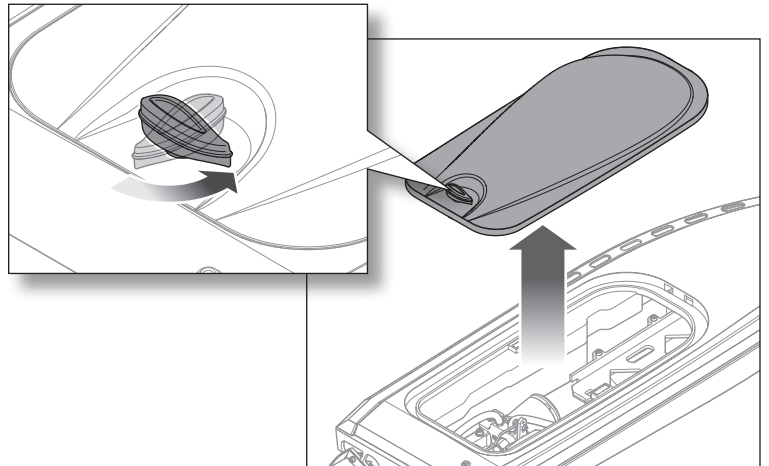

Range Check

IMPORTANT: Perform a range check at the beginning of each boating session, after any repair, or after new battery installation.

Ensure that the battery is fully charged.

1. Place the boat securely on the included stand.
2. With the radio system and boat powered ON and connected, walk 90 feet (32 m) away from the boat.
3. Have an assistant remain with the boat to check for proper steering control movement in response to transmitter inputs.
4. If everything is operating correctly, prepare to operate the boat in the water.

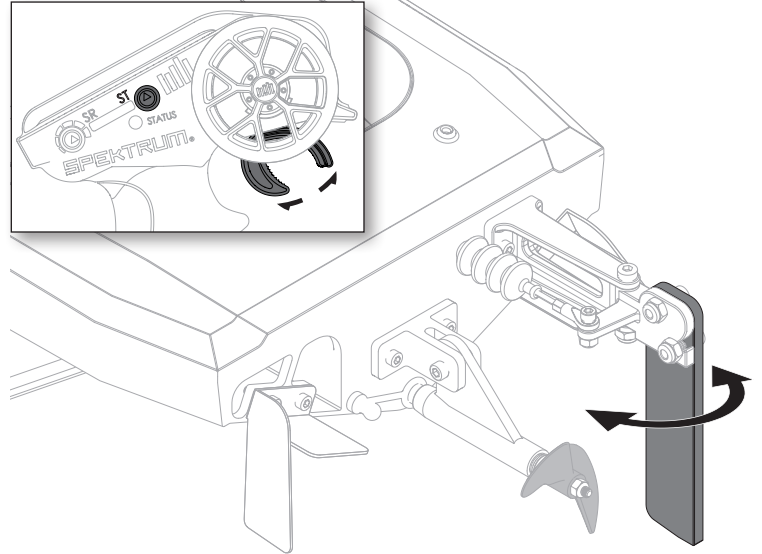

Low Voltage Cutoff (LVC)

The factory default setting for the LVC in the ESC included with your boat is set at 3.2V per cell. Discharging a LiPo battery below 3V per cell may damage your battery. The included ESC protects the boat battery from over-discharge using Low Voltage Cutoff (LVC). Before the battery charge decreases too much, LVC removes power supplied to the motor.

The boat drastically slows or stops completely once LVC is activated. Releasing the throttle and reapplying it will provide a limited amount of power to safely return the boat to shore. Repeated use after LVC is activated will damage the batteries.

Once LVC has been activated, the ESC status light will flash red continuously indicating that the ESC is in LVC mode.

NOTICE: Repeated operation to LVC will damage the battery.

LVC can activate prematurely if you use (1) a low C-rated battery or (2) an old, worn, and/or weak battery.

The average run time using the recommended battery (SPMX32003S30) is approximately 5–7 minutes, depending on throttle usage. Limited run time may indicate worn or weak batteries.

TIP: If you've installed a freshly charged battery and LVC activates within the first minute of operation, replace your worn or weak batteries with the recommended batteries.

TIP: Monitor your boat battery's voltage before and after boating by using a LiPo Cell Voltage Checker (SPMXBC100, sold separately).

Disconnect and remove the LiPo battery from the boat after use to prevent trickle discharge. Charge your LiPo battery to half capacity before storage. During storage, make sure the battery charge does not fall below 3V per cell. LVC does not prevent the battery from over-discharge during storage.

Boating Tips

Consult local laws and ordinances before choosing a location to pilot your boat.

CAUTION: Never attempt to retrieve a downed boat by swimming. If you need to retrieve your boat from the water, use fishing equipment or another boat.

During the first run, we recommend calm wind and water conditions to ensure that the boat is properly set up. Top speed is determined by the battery's ability to efficiently deliver power to the motor via the ESC.

1. Carefully place the boat in the water.

NOTICE: Never operate your boat in less than 12 inches (30.5 cm) of water.

2. Operate the boat at slow speeds near the shoreline. Avoid objects in the water at all times. When the boat is moving forward, ensure water flows out of the coolant outlet.
3. Once you are comfortable operating the boat at slow speeds, it is safe to operate the boat farther from the shore at higher speeds.
4. Bring the boat back to shore when the motor starts to pulse.

In rough water and windy conditions, consider mounting the battery further forward for added stability.

NOTICE: When running at full speed in choppy water, the propeller may quickly exit and re-enter the water repeatedly, subjecting the propeller and drive shaft to stress. Frequent stress may damage the propeller and drive shaft.

Avoid boating near:

- watercraft
- people (swimming areas, fishing areas)
- stationary objects
- waves and wakes
- rapidly moving water
- wildlife
- floating debris
- overhanging trees
- vegetation

Self-Righting

The self-righting feature uses a water ballast system. The ballast works as a controlled breach in the hull. As the ballast fills with water, the weight of the water forces the boat to sink, while the air trapped inside the hull causes enough buoyancy to right the boat.

The boat will self-right automatically, using water ballast.

Once the boat is upright, it will lean to one side. Apply full throttle.

The trapped water will be forced out of the ballast tanks by the boat's forward momentum.

IMPORTANT: Applying throttle during the self-righting process may prevent the boat from turning over.

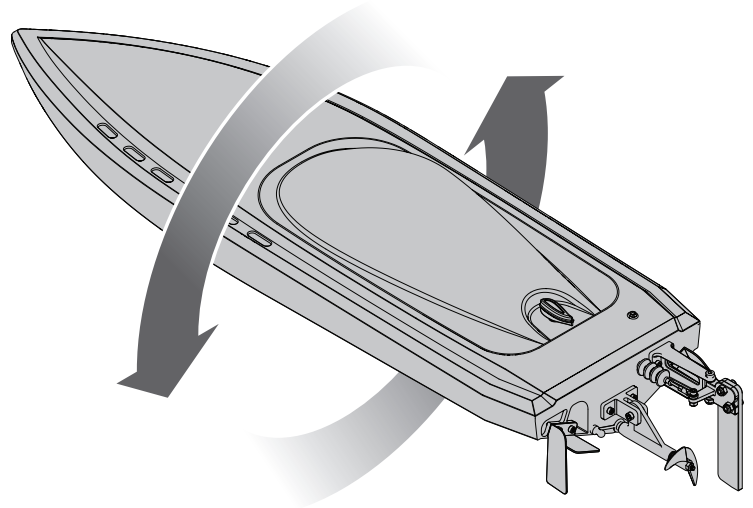

When You Are Finished

NOTICE: When you are finished boating, never leave the boat in direct sunlight or in a hot, enclosed area such as a car. Doing so can damage the boat.

1. Power OFF the receiver by removing the hatch cover and disconnecting the battery lead from the ESC.
2. Power OFF the transmitter.
3. Remove the battery from the boat.
4. Drain any water from the inside of the hull by rotating the boat upside down.
5. Remove the drain plug to remove any water left over. Remove any remaining water with a dry towel.
6. Fully dry the inside and outside of the boat. Carefully dry all battery, motor and receiver connectors by removing one at a time and reinstalling.
7. Remove the hatch before storing your boat.

TIP: Removing the hatch before storage will prevent mold and mildew from growing in the boat.
8. Repair any damage or wear to the boat.
9. Remove the flex shaft, and use a paper towel dry it.
10. Lubricate the flex shaft using Dynamite Marine Grease (DYNE4200).

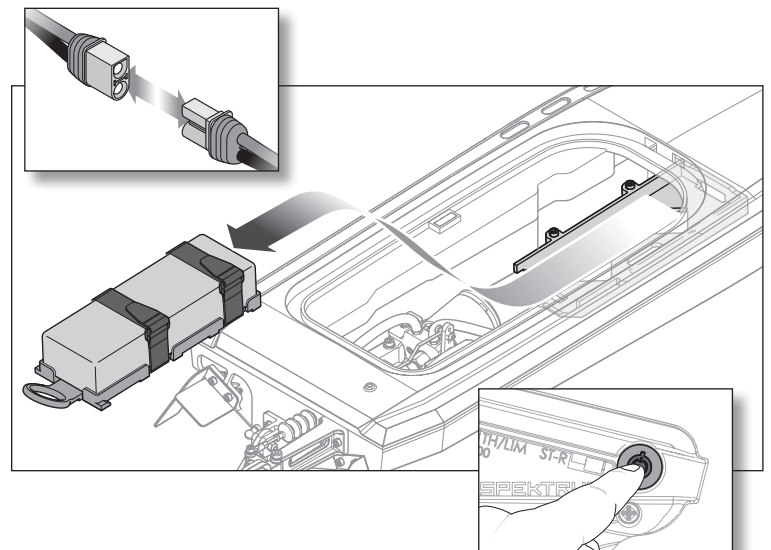

Maintenance

Motor Care

CAUTION: Do not touch the motor until it has had time to cool. It can become extremely hot when in use.

- Prolong motor life by preventing overheating conditions. Undue motor wear results from frequent turns, stops and starts, pushing objects, boating in rough water or vegetation, and boating continuously at high speed.

- Over-temperature protection is installed on the ESC to prevent circuit damage, but cannot protect the motor from pushing against heavy resistance.
- Lubrication is important to prevent motor damage. If your motor gets wet, lubricate the bushings supporting the motor shaft with light duty machine oil. Failure to do so can cause the motor shaft to seize against the motor bushings.

Cooling System

If water does not stream out of the water outlet while the boat is moving forward, immediately stop the boat and clean the obstruction from the water cooling system.

1. Disassemble and clean the water cooling system to remove the blockage and prevent overheating.
2. Replace damaged parts.

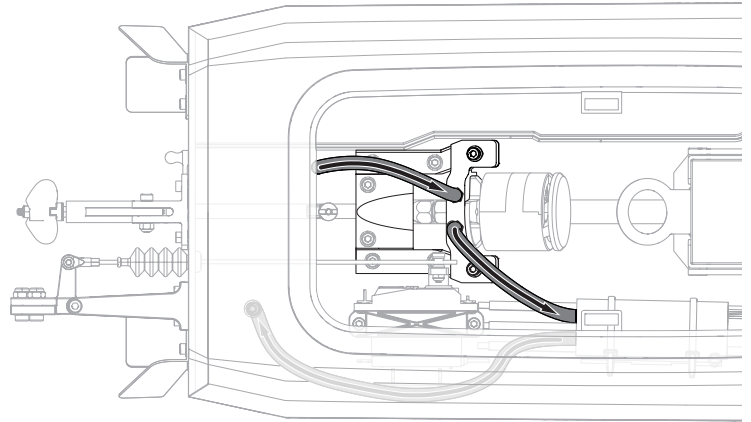

Rudder Service

The **Sonicwake** features a break away rudder designed to swing out if it strikes a solid object.

1. Push the rudder back into place.
2. Use a **2.5mm** hex driver and 5.5mm wrench (Dynamite Pro Boat Tool Set, DYNT0502) to tighten the screws.

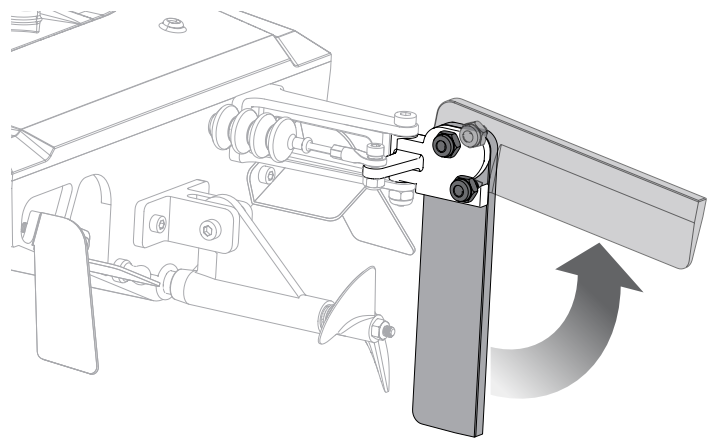

Propeller Service

1. Use an 8mm nut driver (DYN2805) to loosen the nut from the driveshaft.
2. Remove the nut and propeller from the driveshaft.
3. Assemble in reverse order. Correctly align the propeller with the drive dog on the driveshaft.

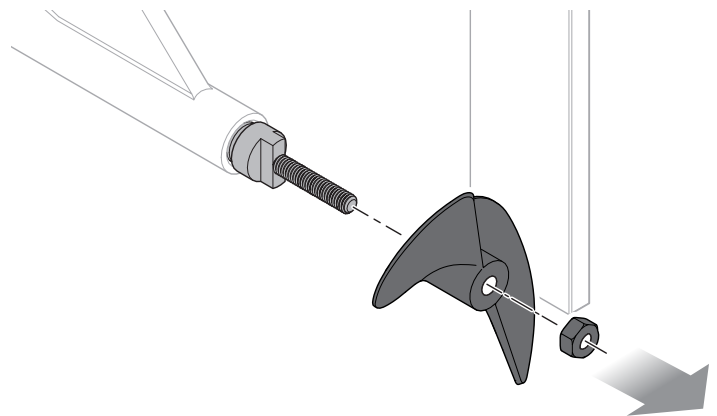

Trim Tabs

The trim tabs come installed from the factory to stabilize the boat as it rides across the water. They are set for consistent performance and stability in most water conditions. However, you can tune out chine walk or porpoise effect by adjusting the trim tabs so they are at least 1–1.5 mm below the ride surface of the boat.

Adjusting the tabs up or down allows the boat to come into more or less contact with the water, resulting in either a smooth, planted ride or a fast, loose ride.

To adjust the angle of the trim tabs:

1. Carefully bend the tab up or down, depending on the desired ride adjustment.

2. Lay a straight edge lengthwise along the bottom of the hull, next to the trim tab. Note the angle of the trim tab compared to the straight edge.
3. Repeat this process on the other side to adjust the second trim tab to match the angle of the first. Use the straight edge to check the adjustments.

IMPORTANT: The trim tabs should be the same distance above or below the boat's ride surface. Adjusting one trim tab more than the other can cause the boat to behave erratically.

NOTICE: If the boat rolls or flips at full speed, the trim tabs or turn fins may bend. Immediately return the boat to shore for inspection.

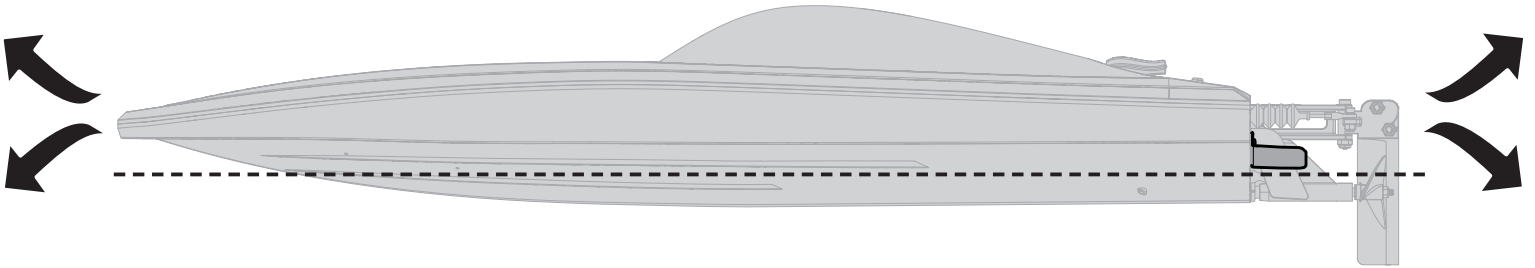

Turn Fin Adjustment

1. Carefully bend the fin in or out, depending on the desired ride adjustment.
2. Repeat on the other side.

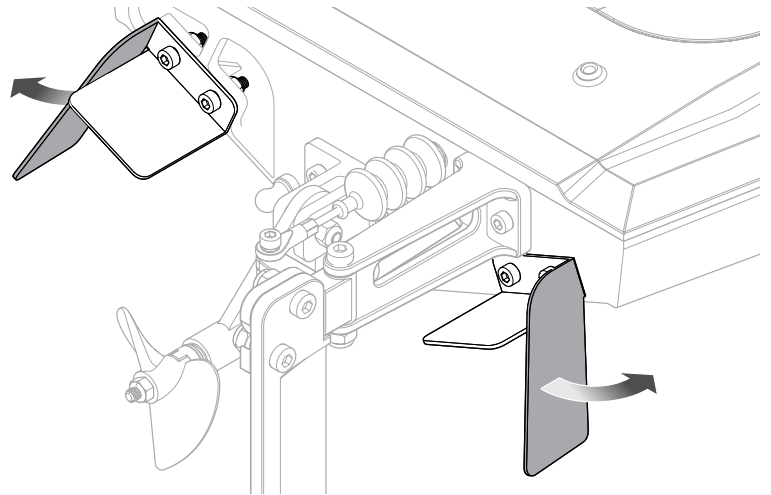

Propeller Angle Adjustment

Raising the drive strut increases speed, but also decreases steering response and increases cavitation.

Lowering the drive strut increases steering response, but also increases steering sensitivity and decreases speed.

1. Loosen the nut and bolt from the drive strut on the rear of the boat.
2. Slide the strut up or down to change the angle of the propeller in relation to the hull.
3. Adjust as desired and tighten the nut and bolt.

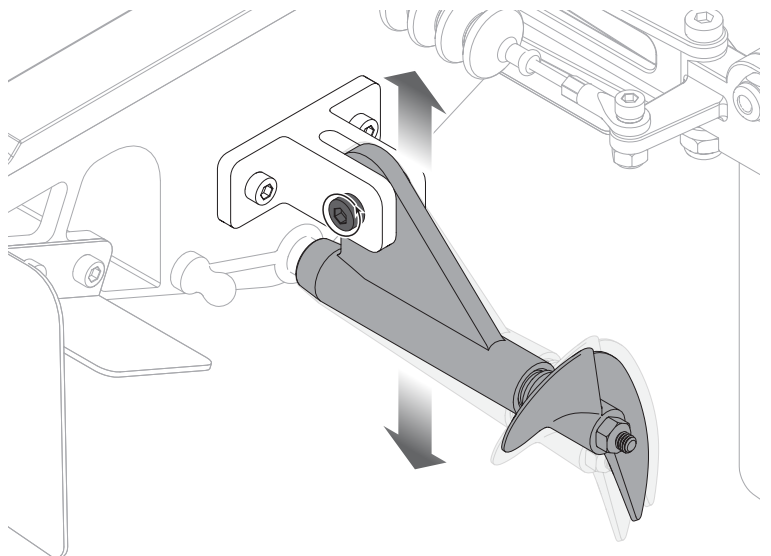

Full Flex Shaft Lubrication

Remove, clean, and lubricate the flex shaft after every boating session. It is good practice to completely remove the flex shaft after a day of running to clean the old grease out and dry any water from the stuffing tube.

1. Use a 2.5mm driver to loosen the two flex shaft/stuffing tube cover screws, then remove the cover.
2. Loosen the flex shaft collet using two 10mm wrenches.
3. Remove the flex shaft by sliding it toward the back of the boat.
4. Use a paper towel to remove old grease and water from the flex shaft and the bushing.
5. Dry any water in the stuffing tube.
6. Use a Dynamite grease gun (DYNE4200) to generously lubricate the bushing and the flex shaft.
7. Reassemble the flex shaft in reverse order.

TIP: Do not add grease to the last 2 inches of the flex shaft. This allows for a better grip inside the collet and prevents the flex shaft from loosening while boating.

NOTICE: Running the boat in saltwater could cause some parts to corrode. If you run the boat in saltwater, rinse it thoroughly in freshwater after each use and lubricate the drive system. Running RC boats in saltwater is at the discretion of the modeler.

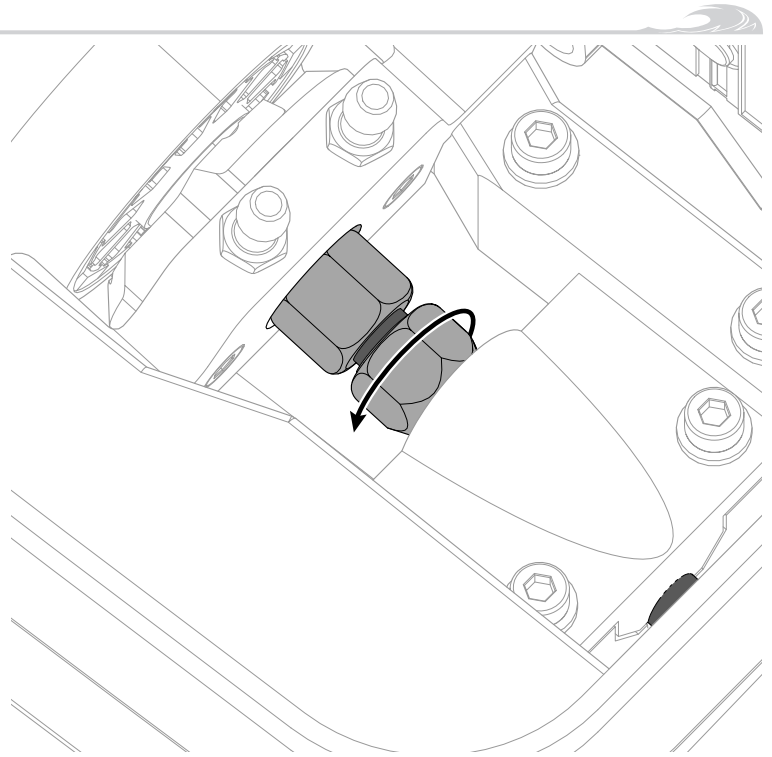

Replacement Parts

PART #	DESCRIPTION
PRB18039	Servo 5.3kg 4.8-6v Waterproof Analog
PRB286104	Quick Battery Base Standard: Pro Boat
PRB286105	Quick Battery Tray Standard: Pro Boat
PRB-3094	Hull, Black/Red
PRB-3096	Canopy Black/Red
PRB-3092	Motor Shaft Coupler
PRB-3091	Stuffing Tube
PRB-3095	Propeller (3)
PRB-3093	Motor Mount Set
PRB-3088	Prop Strut Set
PRB-3087	Turn Fin Set
PRB-3090	Rudder Set
PRB-3089	Servo Mount & Pushrod Set
PRB-3098	Flex Shaft Set
PRB-3097	Hull Seal Set
PRB-3283	Hull, White/Blue
PRB-3284	Canopy White/Blue
SPMSR215	SR215 DSMR 2-Channel Sport Receiver
SPMX-1128	Marine 50A Brushless ESC
SPMX32003S30	11.1V 3200mAh 3S 30C Smart LiPo Battery: IC3
SPMXC1020	Smart S120 USB-C Charger, 1x20W
SPMXMM1600	3542 2500Kv Outrunner Marine Motor: 3.175mm

Optional Parts

PART #	DESCRIPTION
DYN2950	8-in-1 Hex Wrench Kit
DYN4403	GPS Speed Meter 2.0
DYNE0100	Precision Oiler: Medium
DYNE4200	Grease Gun with Marine Grease 5 oz
DYNE4201	Marine Grease 5 oz
DYNF1055	Infrared Temp Gun/Thermometer w/ Laser Sight
DYNM0102	Clear Flexible Marine Tape (18M)
DYNT3010	Nut Driver Wrench Set (4) Metric
DYNT0502	Start Up Tool Set: Pro Boat
SPM2340	DX3 Smart 3-Channel Transmitter with SR315 Receiver
PRB-1658	Universal Propeller Cover: Pro Boat
PRB-3137	Propeller Set, Aluminum
PRB-3147	Complete Hardware Upgrade Set, Aluminum
SPMX-1027	Spektrum 65W USB-C GaN Power Supply
SPMR5025SC	DX5 Pro 5-Channel DSMR Spektrum Certified Transmitter Only
SPMR5115SC	DX5C Spektrum Certified Transmitter Only
SPMX-1027	Spektrum 65W USB-C GaN Power Supply
SPMXBC100	XBC100 SMART Battery Checker & Servo Driver
SPMXC2050	S155 55W AC G2 Smart Charger
SPMXC2090	Smart S100 G2 USB-C Charger
SPMXCA300	Smart LiPo Bag, 16 x 7.5 x 6.5 cm
SPMXCA400	Smart LiPo Bag, 14 x 6.5 x 8 cm

Hardware

QUANTITY	DESCRIPTION
1	M2 x 10mm Cap Head Screw, Stainless Steel
16	M3 x 10mm Cap Head Screw, Stainless Steel
10	M3 x 12mm Cap Head Screw, Stainless Steel
2	M3 x 14mm Cap Head Screw, Stainless Steel
1	M3 x 16mm Cap Head Screw, Stainless Steel

QUANTITY	DESCRIPTION
1	M3 x 25mm Cap Head Screw, Stainless Steel
1	M3 Setscrew, Stainless Steel
12	M3 Locknut, Stainless Steel
1	M2 Locknut, Stainless Steel
3	M3 Washer, Stainless Steel

Troubleshooting Guide

PROBLEM	POSSIBLE CAUSE	SOLUTION
Boat will not respond to throttle but responds to other controls	Throttle channel is reversed	Reverse throttle channel on transmitter
	ESC is not calibrated to transmitter	Perform ESC throttle calibration
Extra noise or extra vibration	Damaged propeller, shaft or motor	Replace damaged parts
	Propeller is out of balance	Balance or replace propeller
	Boat squeals or makes a high pitch sound when applying power to motors	Lubricate flex shaft
Reduced runtime or boat underpowered	Boat battery charge is low	Completely recharge battery
	Boat battery is damaged	Replace boat battery and follow battery instructions
	Blocking or friction on shaft or propeller	Disassemble, lubricate and correctly align parts
	Boat conditions may be too cold	Make sure the battery is warm (above 10° C [50° F]) before use
	Battery capacity may be too low for conditions	Replace battery or use a larger capacity battery
	Drive dog is too near the stuffing tube	Loosen drive shaft side of the motor coupling and move drive shaft small amount back
	Too little lubrication on drive shaft	Fully lubricate drive shaft
	Vegetation or other obstacles block the rudder or propeller	Remove vegetation or obstacles from rudder or propeller
Boat will not bind (during binding) to transmitter	Motor couplers are loose	Tighten motor couplers and ensure the coupler is free of lubrication
	Transmitter is too near boat during binding process	Move powered transmitter a few feet from boat, disconnect and reconnect battery to boat
	Boat or transmitter is too close to large metal object, wireless source or another transmitter	Move the boat and transmitter to another location and attempt binding again
	Another compatible transmitter is powered on within range of the receiver	Power off all compatible transmitters except the one you are trying to bind
	Incorrect binding protocol set	Verify binding procedure and use binding for stock radio. If using a DSMR or DSM2 utilize the standard binding procedure listed in the manual
	Boat battery/transmitter battery charge is too low	Replace/recharge batteries
Boat will not connect (after binding) to transmitter	ESC is off	Power on ESC
	Transmitter is too near boat during connecting process	Move powered transmitter a few feet from boat, disconnect and reconnect battery to boat
	Boat or transmitter is too close to large metal object, wireless source or another transmitter	Move boat or transmitter to another location and attempt to connect again
	Boat battery/transmitter battery charge is too low	Replace/recharge batteries
Boat tends to dive in the water or takes on water	ESC is off	Power on ESC
	Boat hull is not completely closed	Dry out the boat and ensure the hatch is fully closed on the hull before returning the boat to the water
	Trim tabs are adjusted too deep	Adjust trim tabs up
	Center of gravity is too far forward	Move batteries back in the hull

PROBLEM	POSSIBLE CAUSE	SOLUTION
Boat tends to turn one direction	Rudder or rudder trim is not centered	Repair rudder or adjust rudder and rudder trim for straight running when control is at neutral
	Break away rudder system is damaged or broken	Inspect, repair, or replace the rudder system
	Vegetation or debris is stuck to the boat hardware	Remove the debris and retest
Rudder does not move	Rudder, linkage or servo damage	Replace or repair damaged parts and adjust controls
	Steering servo wire is damaged or connections are loose	Check steering servo wires and connections, connect or replace
	Transmitter is not bound correctly	Re-bind
	BEC of the ESC is damaged	Replace ESC
	ESC is off	Power on ESC
Controls reversed	Transmitter settings are reversed	Do the Control Direction Test and adjust controls on transmitter appropriately
Motor overheats	Blocked water cooler tubes	Clean or replace water tubes
Motor power pulses then motor loses power	ESC uses default soft Low Voltage Cutoff (LVC)	Recharge boat battery or replace battery that is no longer performing
	Weather conditions too cold	Postpone until weather is warmer
	Battery is old, worn out or damaged	Replace battery
Boat blows over upon acceleration	Batteries are too far back in the battery tray	Move the batteries forward to adjust the boat's center of gravity
	Struts have too much positive angle, causing the nose of the boat to lift and blow over	Adjust a more neutral or negative strut angle
	Trim Tabs not adjusted, causing the nose of the boat to lift and blow over	Adjust the trim tabs further into the water to keep the nose of the boat in the water and provide additional stability
	Water conditions are too choppy or windy	Adjust the struts downward to drive the bow of the boat down or move the batteries further forward for better weight distribution

2-Year Limited Warranty

What This Warranty Covers — Horizon Hobby, LLC, (Horizon) warrants to the original purchaser that the product purchased (the "Product") will be free from defects in materials and workmanship for two years from the date of purchase.

What is Not Covered — This warranty is not transferable and does not cover (i) cosmetic damage, (ii) damage due to acts of God, accident, misuse, abuse, negligence, commercial use, or due to improper use, installation, operation or maintenance, (iii) modification of or to any part of the Product, (iv) attempted service by anyone other than a Horizon Hobby authorized service center, (v) Product not purchased from an authorized Horizon dealer, or (vi) Product not compliant with applicable technical regulations or (vii) use that violates any applicable laws, rules, or regulations.

OTHER THAN THE EXPRESS WARRANTY ABOVE, HORIZON MAKES NO OTHER WARRANTY OR REPRESENTATION, AND HEREBY DISCLAIMS ANY AND ALL IMPLIED WARRANTIES, INCLUDING, WITHOUT LIMITATION, THE IMPLIED WARRANTIES OF NON-INFRINGEMENT, MERCHANTABILITY AND FITNESS FOR A PARTICULAR PURPOSE. THE PURCHASER ACKNOWLEDGES THAT THEY ALONE HAVE DETERMINED THAT THE PRODUCT WILL SUITABLY MEET THE REQUIREMENTS OF THE PURCHASER'S INTENDED USE.

Purchaser's Remedy — Horizon's sole obligation and purchaser's sole and exclusive remedy shall be that Horizon will, at its option, either (i) service, or (ii) replace, any Product determined by Horizon to be defective. Horizon reserves the right to inspect any and all Product(s) involved in a warranty claim. Service or replacement decisions are at the sole discretion of Horizon. Proof of purchase is required for all warranty claims. SERVICE OR REPLACEMENT AS

PROVIDED UNDER THIS WARRANTY IS THE PURCHASER'S SOLE AND EXCLUSIVE REMEDY.

Limitation of Liability — HORIZON SHALL NOT BE LIABLE FOR SPECIAL, INDIRECT, INCIDENTAL OR CONSEQUENTIAL DAMAGES, LOSS OF PROFITS OR PRODUCTION OR COMMERCIAL LOSS IN ANY WAY, REGARDLESS OF WHETHER SUCH CLAIM IS BASED IN CONTRACT, WARRANTY, TORT, NEGLIGENCE, STRICT LIABILITY OR ANY OTHER THEORY OF LIABILITY, EVEN IF HORIZON HAS BEEN ADVISED OF THE POSSIBILITY OF SUCH DAMAGES. Further, in no event shall the liability of Horizon exceed the individual price of the Product on which liability is asserted. As Horizon has no control over use, setup, final assembly, modification or misuse, no liability shall be assumed nor accepted for any resulting damage or injury. By the act of use, setup or assembly, the user accepts all resulting liability. If you as the purchaser or user are not prepared to accept the liability associated with the use of the Product, purchaser is advised to return the Product immediately in new and unused condition to the place of purchase.

Law — These terms are governed by Illinois law (without regard to conflict of law principals). This warranty gives you specific legal rights, and you may also have other rights which vary from state to state. Horizon reserves the right to change or modify this warranty at any time without notice.

WARRANTY SERVICES

Questions, Assistance, and Services — Your local hobby store and/or place of purchase cannot provide warranty support or service. Once assembly, setup or use of the Product has been started, you must contact your local distributor or Horizon directly. This will enable Horizon to better answer your questions and service you in the event

that you may need any assistance. For questions or assistance, please visit our website at www.horizonhobby.com, submit a Product Support Inquiry, or call the toll free telephone number referenced in the Warranty and Service Contact Information section to speak with a Product Support representative.

Inspection or Services — If this Product needs to be inspected or serviced and is compliant in the country you live and use the Product in, please use the Horizon Online Service Request submission process found on our website or call Horizon to obtain a Return Merchandise Authorization (RMA) number. Pack the Product securely using a shipping carton. Please note that original boxes may be included, but are not designed to withstand the rigors of shipping without additional protection. Ship via a carrier that provides tracking and insurance for lost or damaged parcels, as Horizon is not responsible for merchandise until it arrives and is accepted at our facility. An Online Service Request is available at http://www.horizonhobby.com/content/service-center_render-service-center. If you do not have internet access, please contact Horizon Product Support to obtain a RMA number along with instructions for submitting your product for service. When calling Horizon, you will be asked to provide your complete name, street address, email address and phone number where you can be reached during business hours. When sending product into Horizon, please include your RMA number, a list of the included items, and a brief summary of the problem. A copy of your original sales receipt must be included for warranty consideration. Be sure your name, address, and RMA number are clearly written on the outside of the shipping carton.

NOTICE: Do not ship LiPo batteries to Horizon. If you have any issue with a LiPo battery, please contact the appropriate Horizon Product Support office.

Warranty Requirements — For Warranty consideration, you must include your original sales receipt verifying the proof-of-purchase date. Provided warranty conditions have been met, your Product will be serviced or replaced free of charge. Service or replacement decisions are at the sole discretion of Horizon.

Non-Warranty Service — Should your service not be covered by warranty, service will be completed and payment will be required without notification or estimate of the expense unless the expense exceeds 50% of the retail purchase cost.

By submitting the item for service you are agreeing to payment of the service without notification. Service estimates are available upon request. You must include this request with your item submitted for service. Non-warranty service estimates will be billed a minimum of ½ hour of labor. In addition you will be billed for return freight. Horizon accepts money orders and cashier's checks, as well as Visa, MasterCard, American Express, and Discover cards. By submitting any item to Horizon for service, you are agreeing to Horizon's Terms and Conditions found on our website http://www.horizonhobby.com/content/service-center_render-service-center.

ATTENTION: Horizon service is limited to Product compliant in the country of use and ownership. If received, a non-compliant Product will not be serviced. Further, the sender will be responsible for arranging return shipment of the un-serviced Product, through a carrier of the sender's choice and at the sender's expense. Horizon will hold non-compliant Product for a period of 60 days from notification, after which it will be discarded.

10/15

Warranty and Service Contact Information

COUNTRY OF PURCHASE	HORIZON HOBBY	CONTACT INFORMATION	ADDRESS
United States of America	Horizon Service Center (Repairs and Repair Requests)	servicecenter.horizonhobby.com/RequestForm/	2904 Research Rd. Champaign, Illinois, 61822 USA
	Horizon Product Support (Product Technical Assistance)	productsupport@horizonhobby.com 800-338-4639	
	Sales	websales@horizonhobby.com 800-338-4639	
EU	Horizon Technischer Service	service@horizonhobby.de	Hanskampring 9 D 22885 Barsbüttel, Germany
	Sales: Horizon Hobby GmbH	+49 (0) 4121 2655 100	

FCC Information

FCC ID: Contains BRWSPMSLT200F & BRWSRIRVINGV1

This equipment complies with FCC and IC radiation exposure limits set forth for an uncontrolled environment. This equipment should be installed and operated with minimum distance 20cm between the radiator and/or antenna and your body (excluding fingers, hands, wrists, ankles and feet). This transmitter must not be co-located or operating in conjunction with any other antenna or transmitter.

Supplier's Declaration of Conformity

Pro Boat Sonicwake 24" Brushless Self-Righting Deep-V

RTR (PRB-1992): This device complies with part 15 of the FCC Rules. Operation is subject to the following two conditions: (1) This device may not cause harmful interference, and (2) this device must accept any interference received, including interference that may cause undesired operation.

CAUTION: Changes or modifications not expressly approved by the party responsible for compliance could void the user's authority to operate the equipment.

NOTE: This equipment has been tested and found to comply with the limits for a Class B digital device, pursuant to part 15 of the FCC Rules. These limits are designed to provide reasonable protection against harmful interference in a residential installation.

This equipment generates, uses and can radiate radio frequency energy and, if not installed and used in accordance with the instructions, may cause harmful interference to radio communications. However, there is no guarantee that interference will not occur in a particular installation. If this equipment does cause harmful interference to radio or television reception, which can be determined by turning the equipment off and on, the user is encouraged to try to correct the interference by one or more of the following measures:

- Reorient or relocate the receiving antenna.
- Increase the separation between the equipment and receiver.
- Connect the equipment into an outlet on a circuit different from that to which the receiver is connected.
- Consult the dealer or an experienced radio/TV technician for help.

Horizon Hobby, LLC

2904 Research Rd.

Champaign, IL 61822

Email: compliance@horizonhobby.com

Web: HorizonHobby.com

IC Information

CAN ICES-3 (B)/NMB-3(B)

IC: Contains 6157A-SPMSLT200F & 6157A-SRIRVINGV1

This device contains license-exempt transmitter(s)/receivers(s) that comply with Innovation, Science, and Economic Development Canada's license-exempt RSS(s). Operation is subject to the following 2 conditions:

1. This device may not cause interference.
2. This device must accept any interference, including interference that may cause undesired operation of the device.

Compliance Information for the European Union

EU Compliance Statement:

Pro Boat Sonicwake 24" Brushless Self-Righting Deep-V RTR (PRB-1992): Hereby, Horizon Hobby, LLC declares that the device is in compliance with the following: EU Low Voltage Directive (LVD) 2014/35/EU; EU EMC Directive 2014/30/EU; EU Radio Equipment Directive (RED) 2014/53/EU; RoHS 2 Directive 2011/65/EU; RoHS 3 Directive - Amending 2011/65/EU Annex II 2015/863.

The full text of the EU declaration of conformity is available at the following internet address: <https://www.horizonhobby.com/content/support-render-compliance>.

NOTE: This product contains batteries that are covered under the 2006/66/EC European Directive, which cannot be disposed of with normal household waste. Please follow local regulations.

Wireless Frequency Range and Wireless Output Power:

Transmitter:

2410 - 2480MHz
13.66dBm

Receiver:

2404 - 2476MHz
-1.33dBm

EU Manufacturer of Record:

Horizon Hobby, LLC
2904 Research Road
Champaign, IL 61822 USA

EU Importer of Record:

Horizon Hobby, GmbH
Hanskampring 9
22885 Barsbüttel Germany

WEEE NOTICE:



This appliance is labeled in accordance with European Directive 2012/19/EU concerning waste of electrical and electronic equipment (WEEE). This label indicates that this product should not be disposed of with household waste. It should be deposited at an appropriate facility to enable recovery and recycling.



24" SELF-RIGHTING BRUSHLESS DEEP V RTR

Exploded View
 Explosionszeichnungen
 Vues éclatées
 Viste esplose

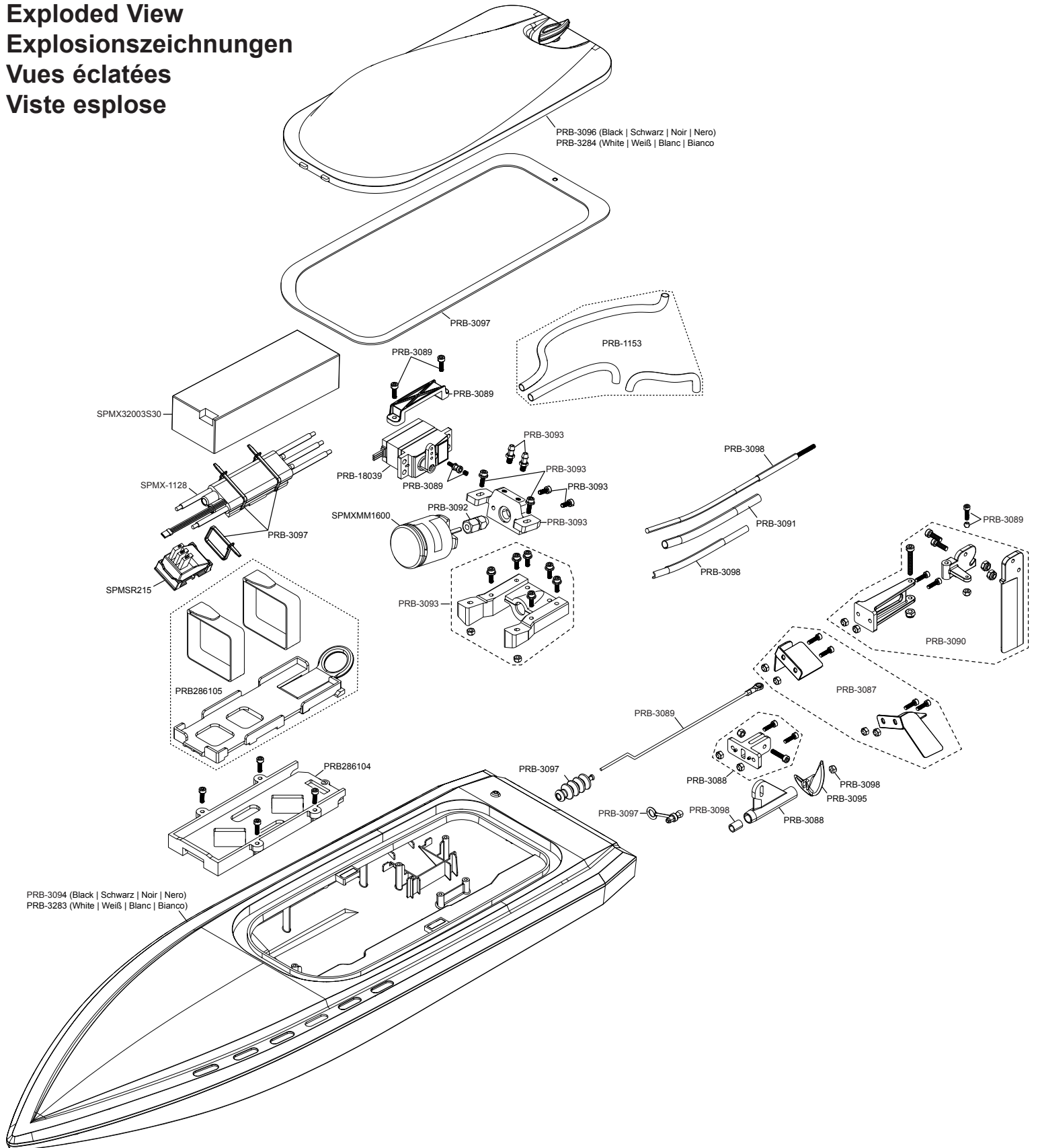



SONICWAKE 24

24" SELF-RIGHTING BRUSHLESS DEEP V RTR



PROBOAT™

©2025 Horizon Hobby, LLC.

Pro Boat, SLT2, IC3, Firma, and the Horizon Hobby logo are trademarks or registered trademarks of Horizon Hobby, LLC.

The Spektrum trademark is used with permission of Bachmann Industries, Inc.

All other trademarks or registered trademarks are property of their respective owners.

Other patents pending.

Created 4/25

PRB-1992

1097855